



**Proud Local
Manufacturer
since 1949**

GBielectric
low voltage

a Reuert company

Switch to Quality



PRICE LIST
2025 / 2026

Switch Ultra

Introducing the new Switch Ultra Range!

A sleek, slimline collection of wiring accessories designed to bring modern style and reliable performance to every space. Locally manufactured with the quality and care you can trust. The range includes switches, plugs, and inserts that combine innovation with everyday practicality. Crafted for those who want more than just functionality, Switch Ultra is where contemporary design meets South African excellence.

Features:

- Thin slimline profile featuring a fluorescent insert
- Available in white and graphite
- Easy and effortless installation and operation
- Locally manufactured
- 12 month warranty
- Fitted with captive screws for ease of installation
- Light switches come standard with 2-way switching
- Same quality - thinner profile

Switch to Quality



Gbi electric
low voltage

a Reuert company



Local
Product

**NEW
RANGE!**



EVERYTHING ASTUTE ON THE GO...

Introducing the Astute Smart Adaptor (ASA) – redefining smart control and automation for a more efficient future!

- » **Wi-Fi and Bluetooth enabled**
- » **Multi function adaptor**
- » **All the functions and features of the Astute Range in a compact, portable configuration**
- » **Remotely control appliances, monitor power usage, set schedules and much more**
- » **Perfect for rental units, simply plug-and-play, no electrician needed!**



**NEW
PRODUCT**



1. Prices

All prices are in Rand and exclusive of VAT. Prices are subject to variation.

2. Ambient Operating Temperature

With CBI Hydraulic-Magnetic Miniature Circuit Breakers, there is no effect on the fixed trip point at ambient temperature ranges from -40°C to +85°C.

3. Certification

Products comply to local and international standards (SANS, VC, IEC, etc.).

4. DC Voltage Rating

Please refer to CBI catalogues / leaflets for DC ratings.

5. For Reverse Feeding

Contact CBI for details.

6. Module Width

CBI's MCB module widths are:

- 13 mm and 26 mm dual mounting (escutcheon height 57 mm).
- 13 mm and 18 mm in DIN rail mounting (escutcheon height 45 mm), Suffix "D" (page 92).

7. Special Breakers

For all breakers manufactured to non-standard requirements, prices will be by quotation only.

8. Standard Current Ratings

Ampere ratings as indicated are standard. Non-standard ratings can be provided – Prices on Request (POR).

9. Switch Disconnectors

All switch disconnectors must be backed up by a suitable short circuit protection device (SCPD), having the same or lower current rating and the same interrupting capacity as the switch disconnector, unless otherwise stated. Contact CBI for availability of 4 Pole switch disconnector units.

10. Motor Starting

Information available in Technical Section.

11. Time Delay Curves

Curve No.	Time Delay	Instantaneous (short circuit)	Must Hold	Current Tripping Current
1	Long	High 10 – 20 x In	1.05 x In	1.30 x In
2	Medium	Medium 5 – 10 x In	1.05 x In	1.30 x In
3	Short	Low 3 – 5 x In	1.05 x In	1.30 x In
2,3 (LL)	Medium	115 % Trip Point (Load Limiting)	1.05 x In	1.15 x In
9	Long	Medium 7 – 12 x In	1.05 x In	1.30 x In
OP (AC + DC)	Instantaneous	Low 3 – 5 x In	1.05 x In	1.30 x In
U2 (DC)	Medium	Medium 6 – 11 x In	1.05 x In	1.30 x In
KM	Medium	Medium 6 – 12 x In	1.05 x In	1.25 x In

Note:
Other curves available on request.

12. Handle Colours

Product Type	Hy-Mag MCBs
Circuit Breakers	White
Curve 1 Circuit Breakers	Orange
Load Limiting Circuit Breakers	Red
Switch Disconnector / Neutral	Green

13. Warranty Claims

Products may only be returned to CBI for warranty claims if all conditions under Section 7, Limitation of Liability, of CBI's General Terms and Conditions of Sale have been met (copy available upon request). The applicable product warranties are depicted in Table 1 on page 113.

INDEX

Astute Range of IoT Products	
Astute Smart Adaptor (ASA) NEW	9
Astute Smart Controller (ASC)	9
Astute Smart Isolator (ASI)	9
Astute Smart Plug (ASP)	9
Astute Smart Plug Dedicated (ASP-D)	9
Astute Smart Power Indicator (ASPI)	9
Wiring Accessories	
Wiring Accessories	10
Switch Ultra Wiring Accessories Range NEW	
Light switches and grid plates	11
Switched socket outlets, unswitched socket outlets and dedicated switched socket outlets	12
Switch disconnectors and switch inserts	13
Wiring Accessories Range	
Light switches and grid plates	14
Switched socket outlets, unswitched socket outlets and dedicated switched socket outlets	15
Outlet boxes, switch disconnectors, TV and telephone outlets, bell push and day / night switches	16
Switch Inserts	
Switch inserts, dimmer switch and dimmer module	17
Switch insert selection guide	18
Technical wiring diagrams	19
Circuit Breakers for Equipment (CBE)	
Photovoltaic and Battery Protection	20
DC range overview	21
B-frame series circuit breaker for equipment	22
C-frame MKIV series circuit breaker for equipment	24
CFM / SFM-frame series circuit breaker for equipment	26
DD-frame series circuit breaker for equipment	28
T-frame series circuit breaker for equipment	30
QDC series circuit breaker for equipment	32
QL series circuit breaker for equipment	34
QT series circuit breaker for equipment	36
QY series circuit breaker for equipment	38
QZ series circuit breaker for equipment	40
YA-frame series circuit breaker for equipment	42
Surge Protection Devices	
Clip-in dual mount surge protection devices	44
Miniature Circuit Breakers (MCB), Earth Leakage Units (ELU)	
MCB Residential Circuit Breakers and Switch Disconnectors	
QA(13) - hydraulic-magnetic	45
QA changeover switches	46
QIL indicator lights	46
QA(13) DIN - hydraulic-magnetic	47
MCB Commercial / Industrial Circuit Breakers and Switch Disconnectors	
QF(13) - hydraulic-magnetic MCBs	48
QF(13) - hydraulic-magnetic switch disconnectors	49
QF(13) DIN - hydraulic-magnetic MCBs	50
QF(13) DIN - hydraulic-magnetic switch disconnectors	51
QF(26) - hydraulic-magnetic low rating	52
QF(26) - hydraulic-magnetic high rating	53
QF(18) DIN - hydraulic-magnetic	54

INDEX

Earth Leakage Units (ELU)	
Residential / Commercial / Industrial Clip-in Earth Leakage Protection Devices	
QF DIN - hydraulic-magnetic earth leakages	55
QA, QF and SF - hydraulic-magnetic earth leakages	56
Commercial / Industrial Earth Leakage Protection Devices	
S-range - hydraulic-magnetic earth leakages	57
MCB Accessories and Auxiliary Products	
MCB accessories	58
MCB accessories, cascading panel labels and auxiliary products	59
Plastic pole mounting box and street light protection	60
Ready boards and distribution boards	61
DIN solar distribution boards	62
DC Protection Kits	63
Circuit breaker selection guide	64
Metering Products	
Rail mount meters	65
Rail mount meters diagrams	66
Moulded Case Circuit Breakers and Accessories	
MCCB Accessories selection chart and dimensions	67
Hydraulic-Magnetic Range	
CBi MCCBs, Switch Disconnectors and Accessories	
JS / JSN and accessories	68
LB / LBN and accessories	69
MB / MBN and accessories	70
Thermal-Magnetic Range	
CBi MCCBs, Switch Disconnectors and Accessories (16 - 250 A)	
GD / GDN / FD / FDN	71
GD / FD accessories	72
F65DV accessories	73
MCCBs and Accessories (250 - 1600 A)	
KD / KDN (thermal-magnetic) and KDE (electronic)	74
KD accessories	75
LDE / LDN and accessories	76
NDE and NDN and accessories	77
Integral Earth Leakage Circuit Breakers 25 kA - 35 kA / Triple Pole DC MCCBs for Traction Control	
ELGD, ELFD and ELKD / DC MCCBs for traction control	78
Industrial and Mining Earth Leakage Relays	
Earth leakage relays, hospital monitors and portable units	79
Mitsubishi Electric MCCBs, ELCBs, Switch Disconnectors and Accessories	
V-series MCCBs and switch disconnectors	80
V-series ELCBs NV (16 - 250 A)	81
V-series MCCBs NF (150 - 400 A)	82
V-Series - Accessories	83
V-series MCCBs and switch disconnectors NF (200 - 1600 A)	84
WSS ELCBs NV (250 - 800 A)	85
WSS accessories	86
Air Circuit Breakers and Accessories	
Mitsubishi Electric Air Circuit Breakers	
Air circuit breakers and switch disconnectors	88
Accessories	89

INDEX

Motor Control	
Mitsubishi Electric Magnetic Contactors	
Series ST / SN	90
Accessories	91
Mitsubishi Electric Thermal Overload Relays	
Series THT / THN	92
Accessories	94
Series ETN	95
Mitsubishi Electric Medium Voltage Vacuum Contactors	
Series SH-V and spares & accessories	96
Series VZ	97
Terminal Blocks	
Terminal blocks	98
Technical Section: Circuit Breakers	
MCBs and accessories data	99
MCB dimensions	100
Motor starting guide	101
DOL starting	102
Star delta starting	103
DOL starting (full load)	104
Terminations and torque settings MCCB	105
Cascading	106
Cascading table 1	107
Cascading table 2	108
Mitsubishi DOL starting	109
Agreed general terms and conditions of sales - Circuit Breaker Industries	110
Notes	113
Circuit Breaker Industries Product Warranty	115

Astute Range of IoT Products



Wi-Fi enabled
Scheduled energy management
Energy monitoring
Automation and IoT
Device automation sharing
CBI Home App and more



www.cbi-lowvoltage.co.za/astute

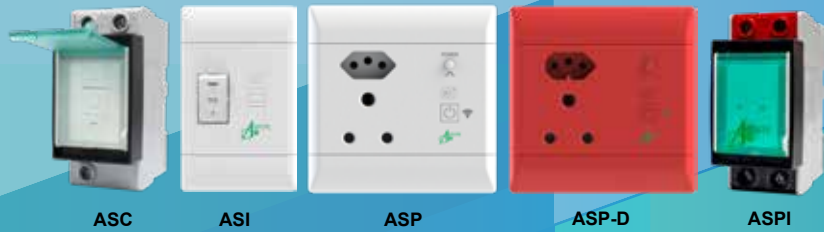

Astute Range				NETT
Order No.	Description	Ratings (A)	Std. Pack	Price Ea. excl. VAT
ASA	NEW Astute Smart Adaptor	16 A	1	R 167.00
ASC	Astute Smart Controller	30 A	1	R 415.00
ASI	Astute Smart Isolator	30 A	1	R 415.00
ASP	Astute Smart Plug	16 A	1	R 415.00
ASP-D	Astute Smart Plug Dedicated	16 A	1	R 415.00
ASPI	Astute Smart Power Indicator	-	1	R 491.00

General

- ▶ Monitor consumption
- ▶ Remotely control devices
- ▶ 7 Day timer function
- ▶ Family sharing
- ▶ Notifications to your smart device

Applications

- ▶ Geyser
- ▶ Pool pumps
- ▶ Underfloor heating
- ▶ Stove
- ▶ Lighting
- ▶ Airconditioners
- ▶ School bells
- ▶ Hydroboilers and instant heaters
- ▶ Hand dryers

Automation

- ▶ Setup timing schedules
- ▶ Setup smart automations to control essential and non-essential loads
- ▶ Use weather conditions to control
- ▶ Use the sunrise and sunset
- ▶ Tap-to-Run multiple devices with one tap
- ▶ Switch your geyser on from your smart device on route back from holiday
- ▶ Switch off device when overcurrent or overvoltage
- ▶ Delay the switching on of devices
- ▶ Load controlling

CBI Home App Information

- ▶ CBI Home App available on the App Store or on Google Play



Requirements

- ▶ 2.4 GHz Wi-Fi with internet connection
- ▶ Smartphone or Tablet

Approvals

- ▶ Compliant to all relevant certifications
- ▶ ICASA



Switch Ultra

Wiring Accessories



Wiring Accessories

Enhancing your lifestyle

SWITCH ULTRA Wiring Accessories Range



SUL121-W



SUL123-W



SUL124-W



SUL125-W

NEW RANGE!

Light Switches (2 x 4 - 250 Vac, 16 A, IP20)						WA
Order No.	Description	Price Ea. excl. VAT	Std. Pack	Order No.	Description	Price Ea. excl. VAT
SUL121-W	1 Lever 2 way light switch white	R 44.00	5	SUL121-G	1 Lever 2 way light switch graphite	R 74.00
SUL123-W	2 Lever 2 way light switch white	R 69.00	5	SUL123-G	2 Lever 2 way light switch graphite	R 107.00
SUL124-W	3 Lever 2 way light switch white	R 71.00	5	SUL124-G	3 Lever 2 way light switch graphite	R 109.00
SUL125-W	4 Lever 2 way light switch white	R 81.00	5	SUL125-G	4 Lever 2 way light switch graphite	R 122.00



SUG021-W

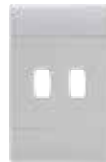

SUG022-W



SUG023-W



SUG024-W



SUG020-W



SUSR024-W

Blanking / Grid Plates 2 x 4						WA
Order No.	Description	Price Ea. excl. VAT	Std. Pack	Order No.	Description	Price Ea. excl. VAT
SUG021-W	2 x 4 Grid plate 1 lever white	R 26.00	10	SUG021-G	2 x 4 Grid plate 1 lever graphite	R 51.00
SUG022-W	2 x 4 Grid plate 2 lever white	R 26.00	10	SUG022-G	2 x 4 Grid plate 2 lever graphite	R 51.00
SUG023-W	2 x 4 Grid plate 3 lever white	R 26.00	10	SUG023-G	2 x 4 Grid plate 3 lever graphite	R 51.00
SUG024-W	2 x 4 Grid plate 4 lever white	R 26.00	10	SUG024-G	2 x 4 Grid plate 4 lever graphite	R 51.00
SUG020-W	2 x 4 Blanking plate white	R 26.00	10	SUG020-G	2 x 4 Blanking plate white graphite	R 51.00
SUSR024-W	2 x 4 Surround 2 piece top & bottom white	R 12.00	10	SUSR024-G	2 x 4 Surround 2 piece top & bottom graphite	R 14.00



SUG040-W



SUG041-W



SUG042-W



SUSR044-W

Blanking / Grid Plates 4 x 4						WA
Order No.	Description	Price Ea. excl. VAT	Std. Pack	Order No.	Description	Price Ea. excl. VAT
SUG040-W	4 x 4 Blanking plate white	R 31.00	10	SUG040-G	4 x 4 Blanking plate graphite	R 64.00
SUG041-W	4 x 4 Grid plate 1 lever white	R 42.00	10	SUG041-G	4 x 4 Grid plate 1 lever graphite	R 78.00
SUG042-W	4 x 4 Grid plate 2 lever white	R 42.00	10	SUG042-G	4 x 4 Grid plate 2 lever graphite	R 78.00
SUSR044-W	4 x 4 Surround 2 piece top & bottom white	R 18.00	10	SUSR044-G	4 x 4 Surround 2 piece top & bottom graphite	R 20.00

Should you require a special combination please contact CBI.

SWITCH ULTRA Wiring Accessories Range

NEW RANGE!



SUP672-W

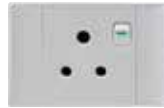

SUP673-W



SUP681-W



Switched Socket Outlets (2 x 4 - 250 Vac, 16 A, IP20)						WA
Order No.	Description	Price Ea. excl. VAT	Std. Pack	Order No.	Description	Price Ea. excl. VAT
SUP672-W	Single switched socket outlet vertical standard white	R 81.00	5	SUP672-G	Single switched socket outlet vertical graphite	R 103.00
SUP673-W	Single switched socket outlet standard horizontal white	R 81.00	5	SUP673-G	Single switched socket outlet horizontal graphite	R 103.00
SUP681-W	SA/EU combined socket outlet vertical white	R 106.00	5	SUP681-G	SA/EU combined socket outlet vertical graphite	R 136.00



SUP674-W



SUP675-W



SUP680-W



SUP683-W



PS685USBC-P



SUP693-W

Socket Outlets (4 x 4 - 250 Vac, 16 A, IP20)						WA
Order No.	Description	Price Ea. excl. VAT	Std. Pack	Order No.	Description	Price Ea. excl. VAT
SUP674-W	Single switched socket outlet white	R 97.00	5	SUP674-G	Single switched socket outlet graphite	R 127.00
SUP675-W	Double switched socket outlet white	R 131.00	5	SUP675-G	Double switched socket outlet graphite	R 164.00
SUP680-W	SA / EU combined switched socket outlet white	R 131.00	5	SUP680-G	SA / EU combined switched socket outlet graphite	R 164.00
SUP683-W	Single socket outlet with 3 x Euro sockets white	R 194.00	5	SUP683-G	Single socket outlet with 3 x Euro sockets graphite	R 233.00
PS685USBC-P	USB Type A & C / SA / Euro switched socket outlet white	R 595.00	5	PS685USBC-G	USB Type A & C / SA / Euro switched socket outlet graphite	R 674.00
SUP693-W	SA / Schuko / Euro combo switched white	R 145.00	5	SUP693-G	SA / Schuko / Euro combo switched graphite	R 179.00



SUP679-W

Unswitched Socket Outlet (250 Vac, 5 A, IP20)				WA
Order No.	Description	Std. Pack	Price Ea. excl. VAT	
SUP679-W	Unswitched socket outlet round white	10	R 41.00	



SUP676-R



SUP677-R

Dedicated Switched Socket Outlet (250 Vac, 16 A, IP20)				WA
Order No.	Description	Std. Pack	Price Ea. excl. VAT	
SUP676-R	4 x 4 Single switched dedicated socket outlet red	5	R 148.00	
SUP677-R	4 x 4 Double switched dedicated socket outlet red	5	R 200.00	

SWITCH ULTRA Wiring Accessories Range



SUI129-W / SUI131-W

NEW RANGE!

Switch Disconnectors (4 x 4 - 2 and 3 Pole, 250 Vac, 60 A, IP20)						WA
Order No.	Description	Price Ea. excl. VAT	Std. Pack	Order No.	Description	Price Ea. excl. VAT
SUI129-W	4 x 4 Stove isolator 2P white	R 159.00	4	SUI129-G	4 x 4 Stove isolator 2P graphite	R 230.00
SUI131-W	4 x 4 Stove isolator 3P white	R 250.00	4	SUI131-G	4 x 4 Stove isolator 3P graphite	R 349.00



SUI130-W

Switch Disconnectors (2 x 4 - 2 Pole, 250 Vac, 30 A, IP20)						WA
Order No.	Description	Price Ea. excl. VAT	Std. Pack	Order No.	Description	Price Ea. excl. VAT
SUI130-W	2 x 4 Geyser isolator 2P white	R 140.00	5	SUI130-G	2 x 4 Geyser isolator 2P graphite	R 206.00



SULI660-P



SULI661-P



SUII663-W

Switch Inserts (IP20)						WA
Order No.	Description	Price Ea. excl. VAT	Std. Pack	Order No.	Description	Price Ea. excl. VAT
SULI660-W	Light switch insert 2 way 16 A white	R 30.00	20	SULI660-G	Switch insert 2 way graphite	R 46.00
SULI661-W	Dimmer switch insert 16 A white	R 35.00	20	SULI661-G	Dimmer switch insert 16 A graphite	R 53.00
SUII663-W	2P switch insert 20 A white	R 84.00	20	SUII663-G	2P switch insert 20 A graphite	R 109.00
SULI664-W	Intermediate switch insert 16 A white	R 120.00	20	SULI664-G	Intermediate switch insert 16 A graphite	R 156.00

Wiring Accessories Range



L120-P / L121-P



L122-P / L123-P



L124-P



L125-P

Light Switches (2 x 4 - 250 Vac, 16 A, IP20)						WA
Order No.	Description	Price Ea. excl. VAT	Std. Pack	Order No.	Description	Price Ea. excl. VAT
L120-P	1 Lever 1 way light switch white	R 41.00	5	L120C03-T	1 Lever 1 way light switch silver shimmer	R 102.00
L121-P	1 Lever 2 way light switch white	R 47.00	5	L121C03-T	1 Lever 2 way light switch silver shimmer	R 107.00
L122-P	2 Lever 1 way light switch white	R 55.00	5	L122C03-T	2 Lever 1 way light switch silver shimmer	R 116.00
L123-P	2 Lever 2 way light switch white	R 72.00	5	L123C03-T	2 Lever 2 way light switch silver shimmer	R 133.00
L124-P	3 Lever 1 way light switch white	R 74.00	5	L124C03-T	3 Lever 1 way light switch silver shimmer	R 135.00
L125-P	4 Lever 1 way light switch white	R 85.00	5	L125C03-T	4 Lever 1 way light switch silver shimmer	R 147.00



L126-P



L127-P

Light Switches (4 x 4 - 250 Vac, 16 A, IP20)						WA
Order No.	Description	Price Ea. excl. VAT	Std. Pack	Order No.	Description	Price Ea. excl. VAT
L126-P	4 Lever 1 way light switch white	R 109.00	5	L126C03-T	4 Lever 1 way light switch silver shimmer	R 190.00
L127-P	6 Lever 1 way light switch white	R 138.00	5	L127C03-T	6 Lever 1 way light switch silver shimmer	R 219.00



G000-P



G001-P



G002-P



G003-P



G009-P



S013R-P

Blanking / Grid Plates 2 x 4						WA
Order No.	Description	Price Ea. excl. VAT	Std. Pack	Order No.	Description	Price Ea. excl. VAT
G000-P	2 x 4 Grid plate 1 lever white	R 28.00	10	G000C03-T	2 x 4 Grid plate 1 lever silver shimmer	R 88.00
G001-P	2 x 4 Grid plate 2 lever white	R 28.00	10	G001C03-T	2 x 4 Grid plate 2 lever silver shimmer	R 81.00
G002-P	2 x 4 Grid plate 3 lever white	R 28.00	10	G002C03-T	2 x 4 Grid plate 3 lever silver shimmer	R 81.00
G003-P	2 x 4 Grid plate 4 lever white	R 28.00	10	G003C03-T	2 x 4 Grid plate 4 lever silver shimmer	R 88.00
G009-P	2 x 4 Blanking plate white	R 28.00	10	G009C03-T	2 x 4 Blanking plate silver shimmer	R 83.00
S013R-P	2 x 4 Surround 2 piece top & bottom	R 12.00	10	N/A		



G004-P



G005-P



G010-P



S014R-P

Blanking / Grid Plates 4 x 4						WA
Order No.	Description	Price Ea. excl. VAT	Std. Pack	Order No.	Description	Price Ea. excl. VAT
G010-P	4 x 4 Blanking plate white	R 32.00	10	G010C03-T	Blanking plate silver shimmer	R 93.00
G004-P	4 x 4 Grid plate 1 lever white	R 44.00	10	G006-P	4 x 4 Grid plate 3 lever white	R 38.00
G005-P	4 x 4 Grid plate 2 lever white	R 44.00	10	G007-P	4 x 4 Grid plate 4 lever white	R 46.00
S014R-P	4 x 4 Surround 2 piece top & bottom	R 19.00	10	G008-P	4 x 4 Grid plate 6 lever white	R 42.00

Should you require a special combination please contact CBI.

Wiring Accessories Range



PS672-P



PS673-P



PS681-P



Switched Socket Outlets (2 x 4 - 250 Vac, 16 A, IP20)						WA
Order No.	Description	Price Ea. excl. VAT	Std. Pack	Order No.	Description	Price Ea. excl. VAT
PS672-P	Single switched socket outlet vertical standard white	R 85.00	5	PS672C03-T	Single switched socket outlet vertical silver shimmer	R 147.00
PS673-P	Single switched socket outlet standard horizontal white	R 85.00	5	PS673C03-T	Single switched socket outlet horizontal silver shimmer	R 147.00
PS681-P	SA/EU combined socket outlet vertical white	R 111.00	5	PS681C03-T	SA/EU combined socket outlet vertical silver shimmer	R 173.00



PS674R-P



PS675R-P



PS680-P



PS682R-P



PS683R-P



PS685USB-P

Socket Outlets (4 x 4 - 250 Vac, 16 A, IP20)						WA
Order No.	Description	Price Ea. excl. VAT	Std. Pack	Order No.	Description	Price Ea. excl. VAT
PS674R-P	Single switched socket outlet white	R 102.00	5	PS674C03-T	Single switched socket outlet silver shimmer	R 183.00
PS675R-P	Double switched socket outlet white	R 138.00	5	PS675C03-T	Double switched socket outlet silver shimmer	R 219.00
PS680-P	SA/EU combined switched socket outlet white	R 138.00	5	PS680C03-T	SA/EU combined switched socket outlet silver shimmer	R 219.00
PS682R-P	6 Way Euro socket outlet	R 138.00	5	N/A		
PS683R-P	Single socket outlet with 3 x Euro sockets	R 204.00	5	N/A		
PS685USB-P	USB / SA / Euro switched socket outlet white	R 625.00	5	PS685USB C03-T	USB / SA / Euro switched socket outlet silver shimmer	R 743.00



PS678-P



PS679-P

Unswitched Socket Outlet (250 Vac, 6 A, IP20)				WA
Order No.	Description	Std. Pack	Price Ea. excl. VAT	
PS678-P	2 x 4 Unswitched socket outlet white	10	R 59.00	
PS679-P	Unswitched socket outlet round white	10	R 43.00	



PS671-P



PS676R-P



PS677R-P

Dedicated Switched Socket Outlet (250 Vac, 16 A, IP20)				WA
Order No.	Description	Std. Pack	Price Ea. excl. VAT	
PS671-P	2 x 4 Single switched dedicated socket outlet horizontal red	5	R 108.00	
PS676R-P	4 x 4 Single switched dedicated socket outlet red	5	R 155.00	
PS677R-P	4 x 4 Double switched dedicated socket outlet red	5	R 211.00	

Wiring Accessories Range



OB690



OB878

Surface Mount Outlet Boxes				WA
Order No.	Description	Std. Pack	Price Ea. excl. VAT	
OB690	Surface mount 2 x 4 outlet box (plastic)	10	R 28.00	
OB878	Surface mount 4 x 4 outlet box (plastic)	10	R 33.00	



I129-P / I131-P

Switch Disconnectors (4 x 4 - 2 and 3 Pole, 250 Vac, 60 A, IP20)							WA
Order No.	Description	Price Ea. excl. VAT	Std. Pack	Order No.	Description	Price Ea. excl. VAT	
I129-P	Stove isolator 2P white	R 167.00	4	I129C03-T	Stove isolator 2P silver shimmer	R 248.00	
I131-P	Stove isolator 3P white	R 331.00	4	I131C03-T	Stove isolator 3P silver shimmer	R 412.00	



I130-P

Switch Disconnectors (2 x 4 - 2 Pole, 250 Vac, 30 A, IP20)							WA
Order No.	Description	Price Ea. excl. VAT	Std. Pack	Order No.	Description	Price Ea. excl. VAT	
I130-P	Geyser isolator 2P white	R 147.00	5	I130C03-T	Geyser isolator 2P silver shimmer	R 207.00	



TV678-P



B133-P



T686-P

TV & Telephone Socket Outlets and Bell Push (2 x 4 - 250 Vac, 16 A, IP20)							WA
Order No.	Description	Price Ea. excl. VAT	Std. Pack	Order No.	Description	Price Ea. excl. VAT	
TV678-P	Single TV socket outlet white	R 157.00	5	TV678C03-T	Single TV socket outlet silver shimmer	R 217.00	
B133-P	Bell push socket outlet white	R 69.00	5	B133C03-T	Bell push socket outlet silver shimmer	R 129.00	
T686-P	Single telephone socket outlet (RJ11) white	R 135.00	5	T686C03-T	Single telephone socket outlet (RJ11) silver shimmer	R 195.00	



NS-116



NS-216



NS-316



NS-416

Day / Night Switches (250 Vac, 25 A, IP54)				AB
Order No.	Description	Std. Pack	Price Ea. excl. VAT	
NS-116	Conduit entry model day / night switch	1	R 195.00	
NS-216	Bracket and cable day / night switch	1	R 200.00	
NS-316	Modular version day / night switch	1	R 200.00	
NS-416	Nema base connection version day / night switch*	1	R 200.00	

* NS-416 does not come complete with the base

Wiring Accessories Range



DI645-P



TI657-P



II662-P



TVI663-P



TVI664-P

Neon, TV, DSTV and Telephone Inserts						WA
Order No.	Description	Price Ea. excl. VAT	Std. Pack	Order No.	Description	Price Ea. excl. VAT
DI645-P	Data socket insert (RJ45)	R 133.00	20	N/A		
TI657-P	Telephone socket insert RJ11 white	R 109.00	20	TI657C03-T	Telephone socket insert RJ11 silver shimmer	R 126.00
II662-P	Indication light insert red	R 53.00	20	N/A		
TVI663-P	Standard TV connection insert white	R 126.00	20	TVI663C03-T	Standard TV connection insert silver shimmer	R 141.00
TVI664-P	DSTV connection insert white	R 124.00	20	TVI664C03-T	DSTV connection insert silver shimmer	R 140.00



LI659-P



LI660-P



LI661-P



LI662-P



LI663-P / II663-P



BI661-P

Switch Inserts (IP20)						WA
Order No.	Description	Price Ea. excl. VAT	Std. Pack	Order No.	Description	Price Ea. excl. VAT
LI659-P	Light switch insert 1 way 16 A white	R 22.00	20	LI659C03-T	Switch insert 1 way silver shimmer	R 38.00
LI660-P	Light switch insert 2 way 16 A white	R 31.00	20	LI660C03-T	Switch insert 2 way silver shimmer	R 47.00
LI661-P	Dimmer switch insert 16 A white	R 36.00	20	LI661C03-T	Dimmer switch insert 16 A silver shimmer	R 53.00
LI662-P	Blank switch insert white	R 7.00	20	LI662C03-T	Blank switch insert silver shimmer	R 22.00
LI663-P	2P switch insert 16 A white	R 64.00	20	LI663C03-T	2P switch insert 16 A silver shimmer	R 81.00
II663-P	2P switch insert 20 A white	R 88.00	20	II663C03-T	2P switch insert 20 A silver shimmer	R 105.00
LI664-P	Intermediate switch insert 16 A white	R 126.00	20	LI664C03-T	Intermediate switch insert 16 A silver shimmer	R 141.00
BI661-P	Bell push insert 4 A white	R 41.00	20	BI661C03-T	Bell push insert 4 A silver shimmer	R 57.00



D500LED-P



D500LEDC-P

Tactile Dimmer Module (LED & Halogen Compatible)				WA
Order No.	Description	Std. Pack	Price Ea. excl. VAT	
D500LED-P	Dimmer module (250 Vac, 500 W)	1	R 645.00	
D500LEDC-P	Complete dimmer unit (G000-P, LI661-P, D500LED-P)	1	R 687.00	

Wiring Accessories Range Grid Plate Selection Guide

Switch to Flexibility...

Wiring Accessories

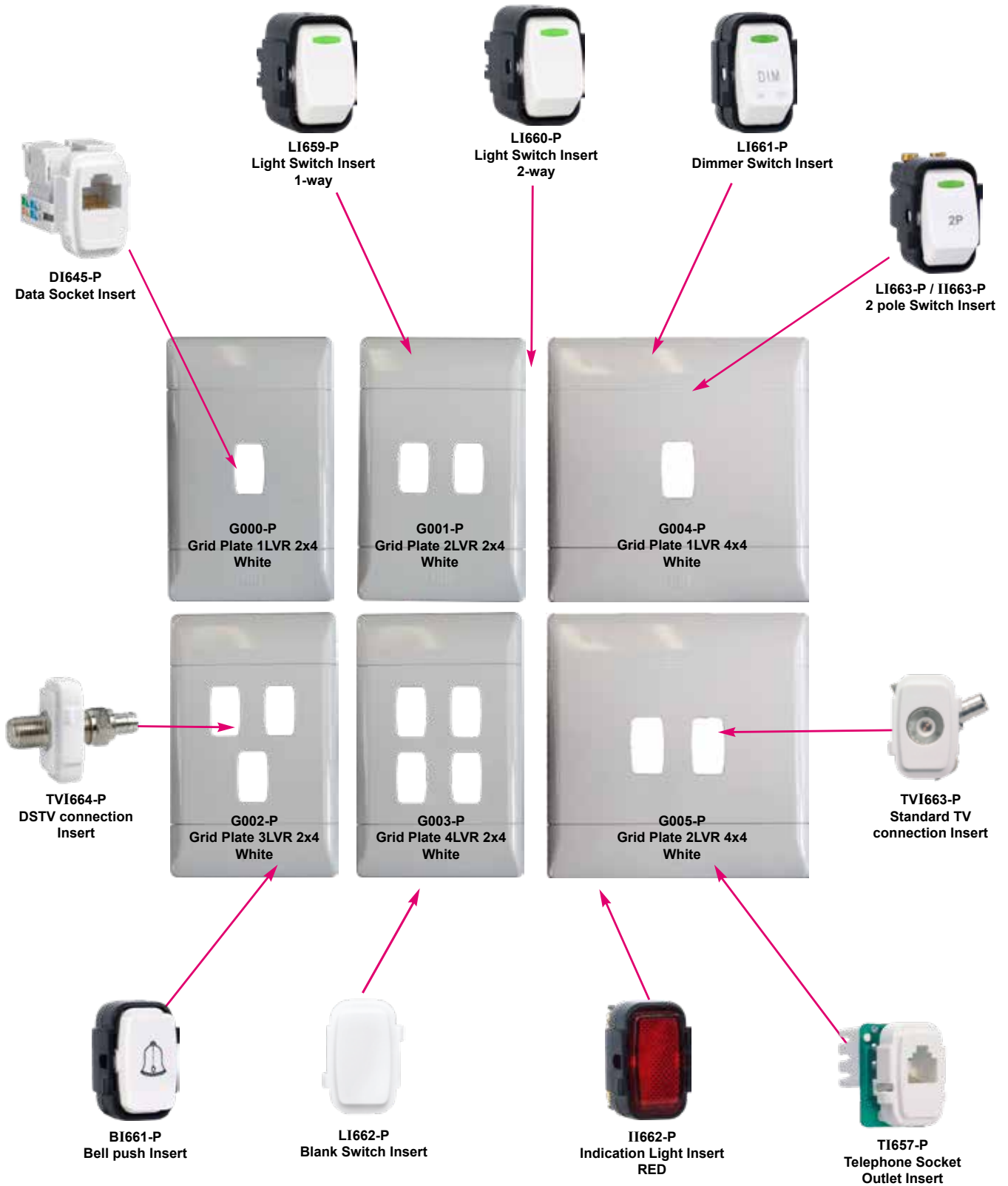

Populate as needed starting from the grid plate as base

D500LED-P Dimmer Trailing Edge

Wiring diagrams

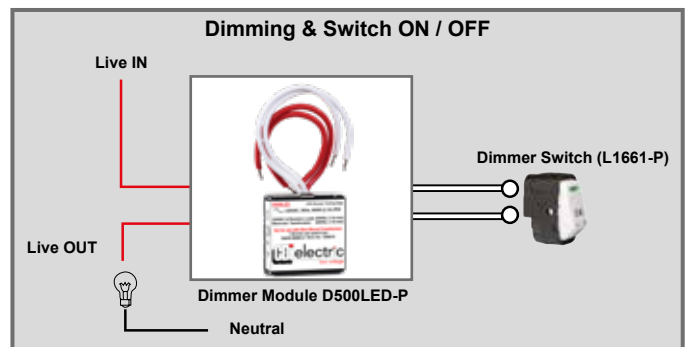
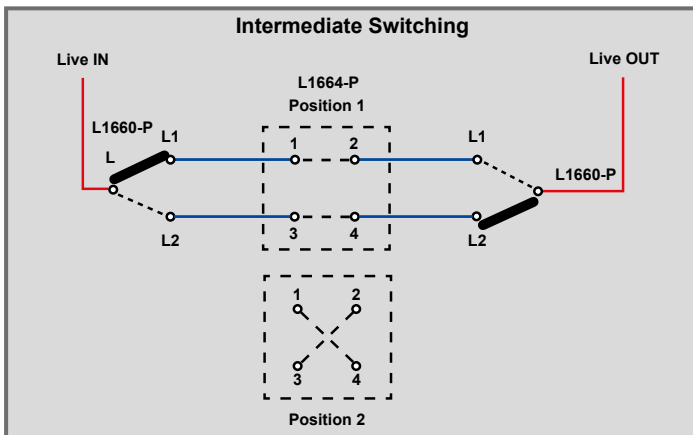
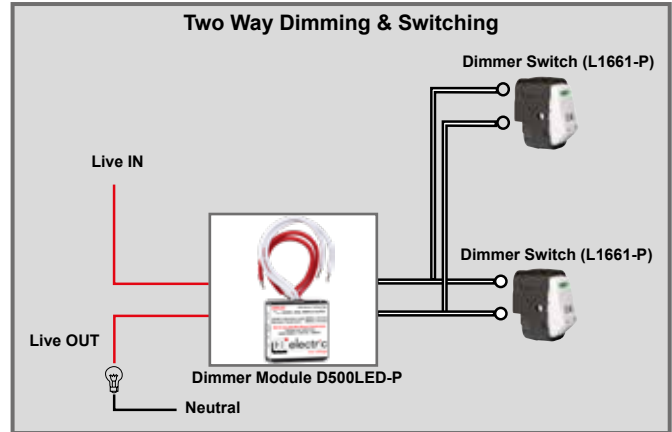
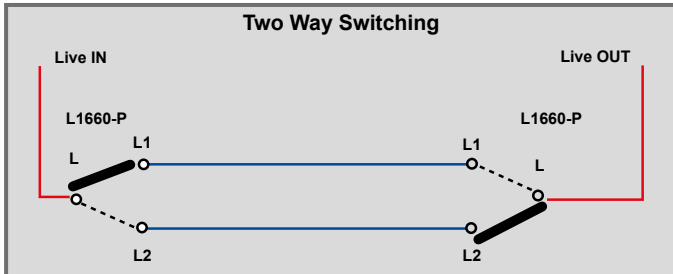

500 W Universal Dimmer (D500LED-P)		WA
Load Tables	Minimum Load	Maximum Load
12 V low voltage electronic transformer	3 W	500 W
230 Vac mains incandescent halogen		500 W
230 Vac mains LED lamps		500 "equivalent" W

Notes:





LED rating of load on dimmers:

Max Watts: Use max replacement wattage. E.g. 3 W LED = 40 W equivalent Watts



Photovoltaic and Battery Protection

Circuit Breakers for Equipment

Photovoltaic and Battery Protection						
Series	Features	Mount	Recommended Application	Module Width	Voltage (up to)	Current (up to)
DD-frame 	<ul style="list-style-type: none"> Hydraulic-magnetic Technology 100% rated Configurable terminals and handle options 	Front Panel (64 mm)	High capacity battery 	1 19 mm	80 Vdc	100 A
				1+1 38 mm	80 Vdc	100 A
				2 38 mm	80 Vdc	200 A
				3 57 mm	80 Vdc	250 A
				4 76 mm	80 Vdc	350 A
QDC(13) 	<ul style="list-style-type: none"> Hydraulic-magnetic Technology 100% rated Trip indication (mid trip) 	DIN rail (45 mm) Dual mount (57 mm) Fits DIN and mini rail	Battery (up to 80 Vdc*)  PV String 	1 13 mm	80 Vdc	63 A
				2 26 mm	125 Vdc*	63 A
					80 Vdc	100 A
				3 39 mm	125 Vdc*	100 A
					250 Vdc*	50 A
4 52 mm	80 Vdc	150 A				
Y-frame 	<ul style="list-style-type: none"> Hydraulic-magnetic Technology 100% rated 	DIN rail (45 mm) Dual mount (57 mm) Fits DIN and mini rail	PV String 	1 13 mm	300 Vdc	50 A
				2 26 mm	600 Vdc	50 A
				1+1 26 mm	300 Vdc	50 A
				2+2 52 mm	600 Vdc	32 A

Watch this space for new products

* QDC(13) 125 Vdc is polarised with respect to current flow and not recommended for battery storage

  or   = excellent

   or    = superior

Notes:

* QDC(13) 125 Vdc is polarised with respect to current flow and not recommended for battery storage

DC Range Overview



QY- Bridged



B-frame



C-frame



DD-frame



RAU

DC Range			
MCCB	Voltages	Current	Fault Level
B-frame	48, 65, 80 Vdc (300 Vdc - switch only, 10 A)	up to 30 A	0.5 kA @ 65 Vdc 0.6 kA @ 80 Vdc
C-frame MKIV	32, 65, 80 Vdc	up to 50 A	4 kA @ 80 Vdc
DD-frame * (RAU option available)	60, 80 Vdc (125 Vdc up to 60 A)	up to 400 A	5 kA @ 60 Vdc, 125 Vdc 10 kA @ 80 Vdc
QY(13) *	80, 125 Vdc (250 Vdc up to 50 A)	up to 200 A	10 kA
JS25	80 Vdc	80 to 250 A	25 kA
JS25S	80 Vdc	300 to 750 A	20 kA
L20B	125 Vdc	800 to 1500 A	20 kA

Notes:

Contact CBI for details.
Full range's data sheets available on www.cbi-lowvoltage.com.
Standard discounts are not applicable.
* DIN rail option available.
Do not remove factory-fitted bridge pieces.

**Insist on
Approval
Certificates!**





B-Frame Series Circuit Breaker for Equipment Hydraulic-Magnetic



Product Type	B-Frame
Ambient Operating Temperature	-40°C to +85°C
Endurance	Minimum of 1 000 operations with current (UL 489A Clause 12)* 6 000 operations with current (UL 1077 Clause 22, UL 508 Clause 48)*
Dielectric Strength	1 000 Vac plus twice the rated voltage for one minute (UL 489A Clause 8, UL 1077 Clause 23, UL 508 Clause 51)*
Rated Impulse Withstand Voltage	2.5 kV (IEC 60934 Clause 8.1.3.1.1)*
Weight	30 g single pole, 60 g double pole (unpacked)
Altitude	Certification tests done at altitude ≈ 2 000 metres. Will operate at higher altitudes.
Shock	50 G to IEC 60068-2-27
Vibration	10 G to MIL-STD-202F
Flammability	I3 - Ignition does not persist at 850°C after glow wire is withdrawn with an oxygen index of ≥ 28
Toxicity	F1 - Smoke index of ≤ 20 which determines the fume class
Pollution Degree	PD2 - Normally only non-conductive pollution occurs. Temporary conductivity caused by condensation is to be expected.
Accessories	Mounting accessories, legend plate

Product Type	Circuit Breaker	Circuit Breaker	Circuit Breaker	Switch
Approvals	UL 1077, DIN/EN 60934, GB 17701, CE, UKCA, EAC	UL 489A, DIN/EN 60934, GB 17701	GB 14048.2	UL 508
Number of Poles	1, 2	1	1, 2	2 (Series)
Maximum Voltages	240 Vac, 65 Vdc	80 Vdc	48 Vdc	300 Vdc
Current Ratings	0.1 - 30 Aac, 0.1 - 25 Adc	0.1 - 30 Adc	0.5 - 15 Adc	15 Adc
Interrupting Capacity	1 kA @ 240 Vac 0.5 kA @ 65 Vdc	0.6 kA @ 80 Vdc 1.5 kA @ 65 Vdc (UL & GB only)	1 kA	-
DC Polarity	-	Polarity sensitive		

Notes:
Verify approvals for specific ratings in accordance with the relevant test certificates.

B-Frame		K6
Type	Poles	Price Ea. excl. VAT
B-FRAME	1	POR
	2	

Handle Configuration		
1	Standard	-
2	Rocker	POR
3	Illuminated Rocker	
4	Push-to-Reset	
5	Push-Pull	

Circuit		
1	Series Trip	-
2	Relay Trip	POR
3	Shunt Trip	

Time Delay		
1	Standard	-
2	Inertia Wheel Curves	POR

Auxiliary Switches		
1	No Auxiliary Switch	-
2	Single Auxiliary Switch	POR

Notes:

POR - Price on Request.
 Additional cost to be added after number of poles.
 Contact CBI for details.
 Please contact CBI for Amp Ratings not listed.
 Full range's data sheets available on www.cbi-lowvoltage.com
 Standard discounts are not applicable.

Approvals

The B-Frame circuit breaker carries various approvals such as VDE, cURus, EAC, CCC and is CE certified. It is also recognised to UL 1077, UL 508 and listed to UL 489A.



C-Frame MKIV Series Circuit Breaker for Equipment Hydraulic-Magnetic



Product Type	C-Frame MKIV
Ambient Operating Temperature	-40°C to +85°C
Endurance	10 000 operations DC; 6 000 operations AC (IEC 60934 Clause 9.11)* 10 000 operations; 6 000 with current, 4 000 without current (UL 489 Clause 7.1.5)* As per UL 489 or minimum of 1 000 operations with current (UL 489A Clause 12)*, 6 000 operations with current (UL 1077 Clause 22)*
Dielectric Strength	1 000 - 2 000 Vac for one minute (Clause 9.7)* 1 000 Vac plus twice the rated voltage for one minute (UL 489, Clause 7.1.9; UL 489A Clause 8, UL 1077 Clause 23)*
Weight	70 g per pole (unpacked)
Altitude	Certification tests done at altitude ≈ 2 000 metres. Will operate at higher altitudes.
Shock	100 G to MIL-STD-202G, test method 213B, test condition 1
Vibration	10 G to MIL-STD-202G test method 204D, test condition A
Flammability	I2 - No ignition at 850°C with an oxygen index of ≥ 32
Toxicity	F1 - Smoke index of ≤ 20 which determines the fume class
Pollution Degree	PD2 - Normally only non-conductive pollution occurs. Temporary conductivity caused by condensation is to be expected.

Product Type	Circuit Breaker	Circuit Breaker	Circuit Breaker	Circuit Breaker
Approvals	UL 489	UL 489A	UL 1077	UL 1500
Number of Poles	1, 2	1, 2	1 - 4	1, 2
Maximum Voltages	120 Vac, 120/240 Vac	80 Vdc	240 Vac, 277 Vac 80 Vdc	120/240 Vac 65 Vdc, 32 Vdc
Current Ratings	0.05 - 20 Aac	0.05 - 50 Adc	0.05 - 50 A (AC & DC)	0.05 - 50 A (AC & DC)
Interrupting Capacity	5 kA	5 kA	2 kA (AC), 7.5 kA (DC)	1.5 kA, C1 & 3 kA, C1

Product Type	Circuit Breaker	Switch
Approvals	DIN/EN/IEC 60934, CE, UKCA, GB 17701	UL 508
Number of Poles	1 - 4	1 - 4
Maximum Voltages	240 Vac, 80 Vdc	240 Vac, 277 Vac, 80 Vdc
Current Ratings	0.05 - 50 A (AC & DC)	50 A
Interrupting Capacity	2 kA (AC), 4 kA (DC)	-

Notes:
Verify approvals for specific ratings in accordance with the relevant test certificates.

C-Frame MKIV		K6
Type	Poles	Price Ea. excl. VAT
C-FRAME MKIV	1	POR
	2	
	3	
	4	

Handle Configuration		
1	Standard	-
2	Rocker	POR
3	DD Adaptor	

Circuit		
1	Series Trip	-
2	Relay Trip	POR
3	Shunt Trip	

Time Delay		
1	Standard	-
2	Inertia Wheel Curves	POR

Auxiliary Switches		
1	No Auxiliary Switch	-
2	Single Auxiliary Switch	POR

Notes:

POR - Price on Request.
 Additional cost to be added after number of poles.
 Contact CBI for details.
 Please contact CBI for Amp Ratings not listed.
 Full range's data sheets available on www.cbi-lowvoltage.com.
 Standard discounts are not applicable.

Approvals

The C-Frame MKIV is CE certified and carries various approvals such as VDE, cURus, EAC and CCC. It is also recognised to UL 1077, UL 1500 and UL 508, and listed to UL 489 and UL 489A.



CFM/SFM-Frame Series Circuit Breaker for Equipment Hydraulic-Magnetic



Product Type	CFM/SFM(26)
Ambient Operating Temperature	-40°C to +85°C
Mounting Options	Clip tray, Front & Surface mounting
Time Delay Curves	1, 2, 3
Endurance	500 mechanical operations (AS/NZS 3111 Clause 7.7)
Dielectric Strength	2 kV (AS/NZS 3111 Clause 7.5.2)
Weight	200 g per pole, 260 g with auxiliary (unpacked)
Altitude	Certification tests done at altitude ≈ 2 000 metres. Will operate at higher altitudes.
Shock	50 g with pulse duration of 11 milliseconds
Vibration	5 g from 35 Hz to 200 Hz
Flammability	I3 - Ignition does not persist at 850°C after glow wire is withdrawn with an oxygen index of ≥ 28
Toxicity	F1 - Smoke index of ≤ 20 which determines the fume class
Pollution Degree	PD2 - Normally only non-conductive pollution occurs. Temporary conductivity caused by condensation is to be expected.

Product Type	Circuit Breaker (AC)				
Approvals	AS/NZS 3111				
Number of Poles	1	2 (1+N)	2	3	4 (3+N)
Operating Voltages	240 Vac		415 Vac		
Minimum Current Rating	4 A				
Maximum Current Rating	100 A				
Interrupting Capacity	6 kA				

Product Type	Circuit Breaker (DC)			
Number of Poles	1	2	3	4
Operating Voltages	125 Vdc			
Minimum Current Rating	1 A			
Maximum Current Rating	100 A			
Interrupting Capacity	6 kA			

Product Type	Switch Disconnecter (AC)			
Approvals	DIN/EN 60947-3			
Number of Poles	1	2	3	4
Operating Voltages	240 Vac	415 Vac		
Current Rating	63 A & 100 A			
Withstand Current	6 kA / 50 ms			

Notes:
Verify approvals for specific ratings in accordance with the relevant test certificates.

CFM/SFM-Frame		K6
Type	Poles	Price Ea. excl. VAT
CFM-FRAME	1	POR
	2	
	3	
	4	

Voltage & Terminal Construction		
A	AC, Back Connect Studs	POR
G	AC, Front Connect Box Term	-
D	AC, Front Connect Screw Term	-
B	DC, Back Connect Studs	POR
H	DC, Front Connect Box Term	-
E	DC, Front Connect Screw Term	-

Circuit		
0	Switch	POR
1	Overload with Auxiliary Switch	
3	Overload	-
5	Shunt Trip (3 terminal)	POR
6	Shunt Trip (4 terminal)	
10	Shunt Trip (flexible leads)	
11	Shunt Trip with Auxiliary Switch	
13	Switch with Auxiliary Switch	

Time Delay		
1	Curve 1 (AS)	POR
2	Curve 2 (BS)	-
3	Curve 3 (CS)	-
P	No time delay (Instantaneous)	-

Additional Features:		
K	Auxiliary OFF Contact	POR
S	Shunt Trip Attachment. (Fitted in an additional 26 mm pole)	

Notes:

POR - Price on Request.
 Additional cost to be added after number of poles.
 Contact CBI for details.
 Please contact CBI for Amp Ratings not listed.
 Full range's data sheets available on www.cbi-lowvoltage.com.
 Standard discounts are not applicable.

Approvals



AS/NZS 3111

DD-Frame Frame Series Circuit Breaker for Equipment Hydraulic-Magnetic



Product Type	DD-Frame
Ambient Operating Temperature	-40°C to +85°C
Endurance	10 000 operations; 1 500 with current, 8 500 without current (IEC 60947-2 Clause 7.2.4.2)* 1 000 operations DC; 6 000 operations AC (IEC 60934 Clause 9.11)* 10 000 operations; 6 000 with current, 4 000 without current (UL 489 Clause 7.1.5)* As per UL 489 or minimum of 1 000 operations with current (UL 489 A Clause 12)* 6 000 operations with current (UL 1077 Clause 22)*
Dielectric Strength	1 000 - 2 000 Vac for one minute (IEC 60947-2 Clause 8.3.3.3, IEC 60934 Clause 9.7)* 1 000 Vac plus twice the rated voltage for one minute (UL 489 Clause 7.1.9, UL 489A Clause 8, UL 1077 Clause 23)*
Rated Impulse Withstand Voltage	4 kV (IEC 60947-2 Clause 8.3.3.2)*
Weight	102 g per pole, 160 g with auxiliary switch (unpacked)
Altitude	Certification tests done at altitude ≈ 2 000 metres. Will operate at higher altitudes.
Shock	100 G to MIL-STD-202G, test method 213B, test condition 1
Vibration	10 G to MIL-STD-202G test method 204D, test condition A
Flammability	I3 - Ignition does not persist at 850°C after glow wire is withdrawn with an oxygen index of ≥ 28
Toxicity	F1 - Smoke index of ≤ 20 which determines the fume class
Pollution Degree	PD2 - Normally only non-conductive pollution occurs. Temporary conductivity caused by condensation is to be expected.

Product Type	Circuit Breaker	Circuit Breaker	Circuit Breaker	Circuit Breaker
Approvals	IEC/EN 60947-2, GB 14048.2, CE, UKCA	IEC/EN 60947-2, GB 14048.2, CE, UKCA	IEC 60947-2, CE, UKCA	AS/NZS 60947-2, IEC 60947-2, CE, UKCA
Number of Poles	1, 2, 3, 4	2 - 5 (parallel)	1, 2 - 3 (parallel)	1, 2
Maximum Voltages	240/415 Vac, 80 Vdc	80 Vdc	60 Vdc	125 Vdc
Current Ratings	0.1 - 60 Aac 0.1 - 100 Adc	110 - 400 A	125 A, 250 A, 300 A	0.1 - 60 A
Ics	5 kA (DC), 1.25 kA (AC),	5 kA	2.5 kA	2.5 kA
Icu	3 kA (AC) 5 kA (AC) 10 kA (DC)	10 kA	5 kA	5 kA

Product Type	Circuit Breaker	Circuit Breaker	Circuit Breaker
Approvals	UL 489	UL 489A, CSA C22.2 No. 5 -16	UL 489A, CSA C22.2 No. 5 -16
Number of Poles	1, 2, 3	1, 2 - 3 (parallel)	2 - 5 (parallel)
Maximum Voltages	120 Vac, 120/240 Vac, 240 Vac, 80 Vdc	60 Vdc	80 Vdc
Current Ratings	0.1 - 80 Aac 0.1 - 100 Adc	125 A, 250 A, 300 A	110 - 400 A
AIC	10 kA (AC), 20 kA (DC)	14 kA	20 kA

Product Type	Circuit Breaker	Circuit Breaker	Switch	Switch
Approvals	IEC/EN 60934, CE, GB 17701, UKCA	UL 1077, cURus	UL 508	IEC/EN 60947-3, CE
Number of Poles	1 - 4	1 - 6	1, 2	1, 2
Maximum Voltages	240/415 Vac, 80 Vdc	277/480 Vac, 80 Vdc	120/240 Vac, 80 Vdc	240 Vac
Current Ratings	0.1 A - 100 A (1 p), 0.1 A - 70 A (2 - 3 p)	.1 A - 100 A (1 p), 0.1 A - 70 A (2 - 4 p)	15 A - 100 A	50 A
Interrupting Capacity	-	2 kA/U2/U3 (AC) 5 kA/C1 (AC) 5 kAU2/U3 (DC)	-	-
Rated conditional S/C	3 kA (AC) PC1, 5 kA (DC) PC1	-	-	-
Icm	-	-	-	0.6 kA (for 1 switch)

Notes:

* Refer to the standard for details

Verify approvals for specific ratings in accordance with the relevant test certificates.

DD-Frame		K6
Type	Poles	Price Ea. excl. VAT
DD-FRAME	1	POR
	2	
	3	
	4	

Handle Configuration		
1	Standard	-
2	Rocker	POR

Time Delay		
1	Standard	-
2	Inertia Wheel Curves	POR

Terminals		
1	Plug-in	POR
2	Flush Rear screw	-
3	Rear studs	-
4	Double Quick connect	-
5	Rail mount	POR

Factory-Fitted Modules		
1	No RAU	-
2	Remote Actuator Unit (RAU)	POR

Circuit		
1	Series Trip	-
2	Relay Trip	POR
3	Shunt Trip	

Auxiliary Switches		
1	No Auxiliary Switch	-
2	Single Auxiliary Switch	POR

Notes:

POR - Price on Request.
Additional cost to be added after number of poles.
Contact CBI for details.
Please contact CBI for Amp Ratings not listed.
Full range's data sheets available on www.cbi-lowvoltage.com.
Standard discounts are not applicable.
Do not remove factory-fitted bridge pieces.

Approvals

The DD-Frame circuit breaker is CE & CCC compliant and carries various approvals such as VDE, cURus, EAC and CCC. It is also recognised to UL 1077 and UL 508, and listed to UL 489 and UL 489A. Compliant with AS/NZS 60947-2.



(UL 489A)

 (UL 489;
CSA C22.2 NO.5)

 (UL 1077;
CSA C22.2 NO.235-04)

(CSA C22.2 No. 5-16)

 (IEC/EN 60947-2;
IEC/EN 60934)

 (GB 14048.2;
GB 17701)

 (IEC 60947-2;
IEC 60934)

(IEC 60947-2)

T-Frame Frame Series Circuit Breaker for Equipment Hydraulic-Magnetic



Product Type	T-Frame
Ambient Operating Temperature	-40°C to +85°C
Mounting Options	Front mounting, rectangular aperture and flush rocker handle type
Endurance	10 000 operations; 1 500 with current, 8 500 without current (IEC 60947-2 Clause 7.2.4.2)* 10 000 operations; 6 000 with current, 4 000 without current (UL 489 Clause 7.1.5)* 6 000 operations with current (UL 1077 Clause 22)*
Dielectric Strength	1 000 - 2 000 Vac for one minute (IEC 60947-2 Clause 8.3.3.3)* 1 000 Vac plus twice the rated voltage for one minute (UL 489 Clause 7.1.9)* 1 000 Vac plus twice the rated voltage for one minute (UL 1077 Clause 23)*
Rated Impulse Withstand Voltage	4 kV (IEC 60947-2 Clause 8.3.3.2)*
Weight	90 g per pole (unpacked)
Altitude	Certification tests done at altitude ≈ 2 000 metres. Will operate at higher altitudes.
Flammability	I3 - Ignition does not persist at 850°C after glow wire is withdrawn with an oxygen index of ≥ 28
Toxicity	F1 - Smoke index of ≤ 20 which determines the fume class
Pollution Degree	PD2 - Normally only non-conductive pollution occurs. Temporary conductivity caused by condensation is to be expected.

Product Type	Circuit Breaker	Circuit Breaker
Approvals	UL 489	DIN/EN 60947-2, GB/T 14048.2, CE, UKCA
Number of Poles	1, 2	1, 2
Maximum Voltages	120/240 Vac, 120 Vdc, 240 Vac, 80 Vdc	240 Vac, 80 Vdc
Current Ratings	0.1 - 30 Aac 0.1 - 30 Adc	0.1 - 30 Aac 0.1 - 30 Adc
Interrupting Capacity	5 kA	5 kA (DC & AC)
AIC	10 kA	

Notes:

* Refer to the standard for details

Verify approvals for specific ratings in accordance with the relevant test certificates.

T-Frame		K6
Type	Poles	Price Ea. excl. VAT
T - FRAME	1	POR
	2	
	3	
	4	

Handle Configuration		
1	Standard	-
2	Rocker	STD
3	Illuminated Rocker	N/A

Circuit		
1	Series Trip	-
2	Relay Trip	N/A
3	Shunt Trip	N/A

Time Delay		
1	Standard	-
2	Inertia Wheel Curves	POR

Auxiliary Switches		
1	No Auxiliary Switch	N/A
2	Single Auxiliary Switch	N/A

Notes:

POR - Price on Request.

Additional cost to be added after number of poles.

Contact CBi for details.

Please contact CBi for Amp Ratings not listed.

Full range's data sheets available on www.cbi-lowvoltage.com.

Standard discounts are not applicable.

Approvals

The T-Frame circuit breaker carries various approvals such as DIN/EN 60947-2, GB 14048.2, VDE, cURus and is CE certified. It is also recognised and listed to UL 489.



QDC Series Circuit Breaker for Equipment Hydraulic-Magnetic



Product Type	QDC
Ambient Operating Temperature	-40°C to +85°C
Mounting Options	Dual (DIN & mini rail) mount & DIN rail mount
Time Delay Curves	1, 9, U2, U3, OP
Endurance	10 000 operations; 1 500 with current, 8 500 without current (IEC 60947-2 Clause 7.2.4.2)*
Dielectric Strength	1 000 - 2 000 Vac for one minute (IEC 60947-2 Clause 8.3.3.3)*
Rated Impulse Withstand Voltage	4 kV (IEC 60947-2 Clause 8.3.3.2)*
Weight	102 g per pole, 160 g with auxiliary (unpacked)
Altitude	Certification tests done at altitude ≈ 2 000 metres. Will operate at higher altitudes.
Shock	16 G (IEC 60068-2-27)
Vibration	2 G (IEC 60068-2-6) (sinusoidal wave)
Flammability	I3 - Ignition does not persist at 850°C after glow wire is withdrawn with an oxygen index of ≥ 28
Toxicity	F1 - Smoke index of ≤ 20 which determines the fume class
Pollution Degree	PD2 - Normally only non-conductive pollution occurs. Temporary conductivity caused by condensation is to be expected.

Approvals	DIN/EN 60947-2, VDE						
Number of Poles	1	2	2 parallel	2 parallel	3 parallel	2 series	4 parallel
Operating Voltages	80 Vdc, 125 Vdc		80 Vdc	125 Vdc	80 Vdc	250 Vdc	80 Vdc
Minimum Current Rating	0.1 A	0.1 A	30 A	30 A	110 A	0.1 A	200 A
Maximum Current Rating	63 A	50 A	100 A	100 A	150 A	50 A	200 A
Ultimate S/C Breaking Capacity (Icu)	10 kA						

Approvals	GB 14048.2						
Number of Poles	1	2	2 parallel	2 parallel	3 parallel	2 series	4 parallel
Operating Voltages	80 Vdc, 125 Vdc		80 Vdc	125 Vdc	80 Vdc	250 Vdc	80 Vdc
Minimum Current Rating	0.1 A	0.1 A	30 A	30 A	110 A	0.1 A	200 A
Maximum Current Rating	63 A	50 A	100 A	100 A	150 A	50 A	200 A
Ultimate S/C Breaking Capacity (Icu)	10 kA						

Notes:

* Refer to the standard for details

Verify approvals for specific ratings in accordance with the relevant test certificates.

QDC Range: 80 Vdc Circuit Breakers, 10 kA, Curve U2, Dual Mount and DIN Rail Mount							K6
Type	Poles	Voltage	kA	MCB Width (mm)	Rating (A)	Price Ea. excl. VAT	Order No. ²
QDC-1(13)-DM-U2-5A-B0 (Grey Handle)	1	80 Vdc	10	13 (1 Module)	5, 6	POR	QDC18U2..B0 *QDD18U2..B0
					10, 15, 20		
					25, 30, 35, 40		
					45, 50, 60		
QDC-2(13)-DM-U2-5A-B0 (Grey Handle)	2	80 Vdc	10	26 (2 Module)	5	POR	QDC28U2..B0 *QDD28U2..B0
					10, 15, 20		
					25, 30, 35, 40		
					45, 50		
QDC-2(13)-DM-U2-080A-B0-ZL (Grey Handle) ¹	2 (Parallel)	80 Vdc	10	26 (2 Module)	80	POR	QDC28U2...B0ZL *QDD28U2...B0ZL
					100		
QDC-3(13)-DM-U2-125A-B0-ZL (Grey Handle) ¹	3 (Parallel)	80 Vdc	10	39 (3 Module)	125	POR	QDC38U2...B0ZL *QDD38U2...B0ZL
					150		
QDC-4(13)-DM-U2-200A-B0-ZL (Grey Handle) ¹	4 (Parallel)	80 Vdc	10	52 (4 Module)	200	POR	QDC48U2200B0ZL *QDD48U2200B0ZL

QDC Range: 125 Vdc Circuit Breakers, 10 kA, Curve U2, Dual Mount and DIN Rail Mount							K6
Type	Poles	Voltage	kA	MCB Width (mm)	Rating (A)	Price Ea. excl. VAT	Order No. ²
QDC-1(13)-DM-U2-5A-B1 (Grey Handle)	1	125 Vdc	10	13 (1 Module)	5	POR	QDC18U2..B1 *QDD18U2..B1
					10, 15, 20		
					25, 30, 35, 40		
					45, 50, 60		
QDC-2(13)-DM-U2-5A-B1 (Grey Handle)	2	125 Vdc	10	26 (2 Module)	5	POR	QDC28U2..B1 *QDD28U2..B1
					10, 15, 20		
					25, 30, 35, 40		
					45, 50		
QDC-2(13)-DM-U2-080A-B1-ZL (Grey Handle) ¹	2 (Parallel)	125 Vdc	10	26 (2 Module)	80	POR	QDC28U2...B1ZL *QDD28U2...B1ZL
					100		

QDC Range: 250 Vdc Circuit Breakers, 10 kA, Curve U2, Dual Mount and DIN Rail Mount							K6
Type	Poles	Voltage	kA	MCB Width (mm)	Rating (A)	Price Ea. excl. VAT	Order No.
QDC-2(13)-DM-U2-5A-B3-T (Grey Handle)	2 (Series)	250 Vdc	10	26 (2 Module)	5	POR	QDC28U2..B3T *QDD28U2..B3T
					10, 15, 20		
					25, 30, 35, 40		
					45, 50		

Accessories

1	Auxiliary Switch	POR
2	Trip Alarm Switch	
3	1 Auxiliary Switch + Trip Alarm	

- Notes:
- Do not remove factory-fitted bridge pieces
 - QDC - Dual mount, 57 mm escutcheon, QDD - DIN rail mount, 45 mm escutcheon - to order DIN version, replace QDC with QDD in Order no POR - Price on Request.

Contact CBI for details.

Please contact CBI for Amp Ratings not listed.

Full range's data sheets available on www.cbi-lowvoltage.com.

Standard discounts are not applicable.

* DIN rail option.

*QDD / DIN rail mount only has the auxiliary switch module available as an accessory

Approvals



QL Series Circuit Breaker for Equipment Hydraulic-Magnetic



Product Type	QL
Ambient Operating Temperature	-40°C to +85°C
Mounting Options	DIN rail mount, Dual (DIN & mini rail) mount, Surface mounting clip
Time Delay Curves	1, 3, 9, KM, OP
Endurance	10 000 operations; 1 500 electrical at rated current, 8 500 without current (IEC 60947-2 Clause 7.2.4.2)* 6 000 electrical operations (UL 489 Clause 7.1.9)*
Dielectric Strength	1 000 - 2 000 Vac for one minute (IEC 60947-2 Clause 8.3.3.3)* 1 000 Vac plus twice the rated voltage for one minute (UL 489 Clause 7.1.9)*
Rated Impulse Withstand Voltage	4 kV (IEC 60947-2)
Weight	102 g per pole, 160 g with auxiliary (unpacked)
Altitude	Certification tests done at altitude ≈ 2 000 metres. Will operate at higher altitudes.
Shock	8 G (IEC 60068-2-27)
Vibration	0.5 G (IEC 60068-2-6) (sinusoidal wave)
Flammability	I3 - Ignition does not persist at 850°C after glow wire is withdrawn with an oxygen index of ≥ 28
Toxicity	F1 - Smoke index of ≤ 20 which determines the fume class
Pollution Degree	PD2 - Normally only non-conductive pollution occurs. Temporary conductivity caused by condensation is to be expected.

Product Type	Circuit Breaker			
Approvals	UL 489			
Number of Poles	1	1	2	2 & 3
Operating Voltages	120 Vac	240 Vac	120/240 Vac	240 Vac
Minimum Current Rating	0.5 A			
Maximum Current Rating	25 A	20 A	25 A	25 A
Ampere Interrupting Capacity (AIC)	10 kA	5 kA	10 kA	10 kA

Product Type	Circuit Breaker				
Approvals	DIN/EN 60947-2, CE, UKCA				
Number of Poles	1	2 (1+N)	2	3	4 (3+N)
Operating Voltages	240 Vac		415 Vac		
Minimum Current Rating	0.5 A				
Maximum Current Rating	25 A				
Ultimate S/C Breaking Capacity (Icu)	6 kA				

Product Type	Circuit Breaker				
Approvals	GB 14048.2				
Number of Poles	1	2 (1+N)	2	3	4 (3+N)
Operating Voltages	240 Vac		415 Vac		
Minimum Current Rating	1 A				
Maximum Current Rating	25 A				
Specific Ratings (Verify Certification)	1, 2, 3, 4, 5, 6, 7, 8, 9, 10, 12, 15, 16, 20, 25 A				
Ultimate S/C Breaking Capacity (Icu)	6 kA				

Notes:
* Refer to the standard for details
Verify approvals for specific ratings in accordance with the relevant test certificates.

QL Range: 240/415 Vac Circuit Breakers, 6 kA, Curve 1, 3, 9, KM & OP Dual Mount and DIN Rail Mount							K6
Type	Poles	Voltage	kA	MCB Width (mm)	Rating (A)	Price Ea. excl. VAT	Order No.
QL-1(13)-DM-C1-5A (White Handle)	1	240 Vac	6	13 (1 Module)	0.5, 1, 2, 3, 4, 5	POR	QL181.. *QLD181..
					6, 7, 8, 9, 10, 12, 15		
					16, 20, 25		
QL-2(13)-DM-C1-5A (White Handle)	2	415 Vac	6	26 (2 Modules)	0.5, 1, 2, 3, 4, 5		QL281.. *QLD281..
					6, 7, 8, 9, 10, 12, 15		
					16, 20, 25		
QL-3(13)-DM-C1-5A (White Handle)	3	415 Vac	6	39 (3 Modules)	0.5, 1, 2, 3, 4, 5		QL381.. *QLD381..
					6, 7, 8, 9, 10, 12, 15		
					16, 20, 25		

Accessories

1	Auxiliary switch	POR
---	------------------	-----

Notes:

POR - Price on Request.
 Auxiliary switch modules priced separately.
 Contact CBI for details.
 Please contact CBI for Amp Ratings not listed.
 Full range's data sheets available on www.cbi-lowvoltage.com.
 Standard discounts are not applicable.
 * DIN rail option.

Approvals



QT Series Circuit Breaker for Equipment Hydraulic-Magnetic



Product Type	QT(26)
Ambient Operating Temperature	-40°C to +85°C
Mounting Options	Dual (DIN & mini rail) mount
Time Delay Curves	1, U2
Endurance	10 000 operations; 1 500 with current, 8 500 without current (IEC 60947-2 Clause 7.2.4.2)* Minimum of 1 000 operations with current (UL 489A Clause 12)*
Dielectric Strength	1 000 - 2 000 Vac for one minute (IEC 60947-2 Clause 8.3.3.3)* 1 000 Vac plus twice the rated voltage for one minute (UL 489A Clause 8)*
Rated Impulse Withstand Voltage	4 kV (IEC 60947-2 Clause 8.3.3.2)*
Weight	200 g per pole (unpacked)
Altitude	Certification tests done at altitude ≈ 2 000 metres. Will operate at higher altitudes.
Shock	50 G to MIL-STD-202G, test method 213B, test condition 1
Vibration	10 G to MIL-STD-202G, test method 204D, test condition A
Flammability	I3 - Ignition does not persist at 850°C after glow wire is withdrawn with an oxygen index of ≥ 28
Toxicity	F1 - Smoke index of ≤ 20 which determines the fume class
Pollution Degree	PD2 - Normally only non-conductive pollution occurs. Temporary conductivity caused by condensation is to be expected.

Product Type	Circuit Breaker			
Approvals	UL 489A, CSA C22.2 No. 5 -16			
Number of Poles	1	2	2 pole bridged	4 pole (2 pole + 2 pole parallel) Parallel Bridged
Operating Voltages	80 Vdc			
Standard Current Rating	70 A to 125 A		250 A	250 A
Interrupting S/C Capacity (Ics)	10 kA			

Product Type	Circuit Breaker			
Approvals	GB 14048-2, DIN/EN 60947-2, CE, UKCA			
Number of Poles	1	2	2 pole bridged	4 pole (2 pole + 2 pole parallel) Parallel Bridged
Operating Voltages	80 Vdc			
Minimum Current Rating	70 A		140 A	
Maximum Current Rating	125 A		250 A	
Interrupting S/C Capacity (Ics)	5 kA			
Ultimate S/C Breaking Capacity (Icu)	10 kA			

Product Type	Circuit Breaker			
Approvals	AS/NZS 60947-2			
Number of Poles	1	2	2 pole bridged	4 pole (2 pole + 2 pole parallel) Parallel Bridged
Operating Voltages	80 Vdc			
Minimum Current Rating	70 A		140 A	
Maximum Current Rating	125 A		250 A	
Interrupting S/C Capacity (Ics)	5 kA			2.5 kA
Ultimate S/C Breaking Capacity (Icu)	10 kA			

Notes:

* Refer to the standard for details

Verify approvals for specific ratings in accordance with the relevant test certificates.

QT Range: 80 Vdc Circuit Breakers, 10 kA, Curve U2, Dual Mount and Surface Mount							K6
Type	Poles	Voltage	kA	MCB Width (mm)	Rating (A)	Price Ea. excl. VAT	Order No.
QT-1(26)-DM-U2-70A-B0 (White Handle)	1	80 Vdc	10	26 (1 Module)	70, 80	POR	QT18U2...B0
					90, 100		
					125		
QT-2(26)-DM-U2-70A-B0 (White Handle)	2	80 Vdc	10	52 (2 Module)	70, 80		QT28U2...B0
					90, 100		
					125		
QT-2(26)-DM-U2-200A-B0-ZL (White Handle) ¹	2 (Parallel)	80 Vdc	10	52 (2 Module)	200		QT29U2200B0ZL
QT-2(26)-DM-U2-250A-B0-ZL (White Handle) ¹	2 (Parallel)	80 Vdc	10	52 (2 Module)	250		QT28U2250B0ZL

Notes:

POR - Price on Request.

Contact CBI for details.

Please contact CBI for Amp Ratings not listed.

Full range's data sheets available on www.cbi-lowvoltage.com.

Standard discounts are not applicable.

1. Do not remove factory-fitted bridge pieces.

Approvals



AS/NZS 60947-2

QY Series Circuit Breaker for Equipment Hydraulic-Magnetic



Product Type	QY
Ambient Operating Temperature	-40°C to +85°C
Mounting Options	Dual (DIN & mini rail) mount, Surface mounting clip
Time Delay Curves	1, 9, U2, U3, OP
Endurance	10 000 operations; 1 500 with current, 8 500 without current (IEC 60947-2 Clause 7.2.4.2)* Minimum of 1 000 operations with current (UL 489A Clause 12)*
Dielectric Strength	1 000 - 2 000 Vac for one minute (IEC 60947-2 Clause 8.3.3.3)* 1 000 Vac plus twice the rated voltage for one minute (UL 489A Clause 8)*
Rated Impulse Withstand Voltage	4 kV (IEC 60947-2 Clause 8.3.3.2)*
Weight	102 g per pole, 160 g with auxiliary (unpacked)
Altitude	Certification tests done at altitude ≈ 2000 metres. Will operate at higher altitudes.
Shock	16 G (IEC 60068-2-27)
Vibration	2 G (IEC 60068-2-6) (sinusoidal wave)
Flammability	I3 - Ignition does not persist at 850 °C after glow wire is withdrawn with an oxygen index of ≥ 28
Toxicity	F1 - Smoke index of ≤ 20 which determines the fume class
Pollution Degree	PD2 - Normally only non-conductive pollution occurs. Temporary conductivity caused by condensation is to be expected.

Approvals	DIN/EN 60947-2						
Number of Poles	1	2	2 parallel	2 parallel	3 parallel	4 parallel	2 series
Operating Voltages	80 Vdc, 125 Vdc		80 Vdc	125 Vdc	80 Vdc		250 Vdc
Minimum Current Rating	0.1 A	0.1 A	30 A	30 A	110 A	200 A	0.1 A
Maximum Current Rating	63 A	50 A	100 A	100 A	150 A	200 A	50 A
Ultimate S/C Breaking Capacity (Icu)	10 kA						

Approvals	UL 489A, CSA C22.2 No. 5 - 16							
Number of Poles	1	2	2 parallel	2 parallel	3 parallel	4 parallel	2 series	4 series
Operating Voltages	80 Vdc, 125 Vdc		80 Vdc	125 Vdc	80/125 Vdc	80 Vdc	250 Vdc	600 Vdc
Minimum Current Rating	0.1 A	0.1 A	30 A	20 A	110 A	200 A	0.1 A	0.1 A
Maximum Current Rating	63 A	50 A	100 A	100 A	150 A	200 A	50 A	20 A
Ampere Interrupting Capacity (AIC)	10 kA							2.5 kA

Approvals	GB 14048.2						
Number of Poles	1	2	2 parallel	2 parallel	3 parallel	4 parallel	2 series
Operating Voltages	80 Vdc, 125 Vdc		80 Vdc	125 Vdc	80 Vdc		250 Vdc
Minimum Current Rating	0.1 A	0.1 A	30 A	30 A	110 A	200 A	0.1 A
Maximum Current Rating	63 A	50 A	100 A	100 A	150 A	200 A	50 A
Ultimate S/C Breaking Capacity (Icu)	10 kA						

Notes:

* Refer to the standard for details

Verify approvals for specific ratings in accordance with the relevant test certificates.

QY Range: 80 Vdc Circuit Breakers, 10 kA, Curve U2, Dual Mount and DIN Rail Mount **K6**

Type	Poles	Voltage	kA	MCB Width (mm)	Rating (A)	Price Ea. excl. VAT	Order No.
QY-1(13)-DM-U2-5A-B0 (White Handle)	1	80 Vdc	10	13 (1 Module)	5, 6	POR	QY18U2..B0 *QYD18U2..B0
					10, 15, 16, 20		
					25, 30, 32, 35, 40		
					45, 50, 60		
QY-2(13)-DM-U2-5A-B0 (White Handle)	2	80 Vdc	10	26 (2 Module)	5, 6	POR	QY28U2..B0 *QYD28U2..B0
					10, 15, 16, 20		
					25, 30, 32, 35, 40		
QY-2(13)-DM-U2-080A-B0-ZL (White Handle) ¹	2 (Parallel)	80 Vdc	10	26 (2 Module)	80	POR	QY28U2...B0ZL *QYD28U2...B0ZL
					100		
QY-3(13)-DM-U2-080A-B0-ZL (White Handle) ¹	3 (Parallel)	80 Vdc	10	39 (3 Module)	125	POR	QY38U2...B0ZL *QYD38U2...B0ZL
					150		
QY-4(13)-DM-U2-200A-B0-ZL (Grey Handle) ¹	4 (Parallel)	80 Vdc	10	52 (4 Module)	200	POR	QY49U2200B0ZL *QYD49U2200B-0ZL

QY Range: 125 Vdc Circuit Breakers, 10 kA, Curve U2, Dual Mount and DIN Rail Mount **K6**

Type	Poles	Voltage	kA	MCB Width (mm)	Rating (A)	Price Ea. excl. VAT	Order No.
QY-1(13)-DM-U2-5A-B1 (White Handle)	1	125 Vdc	10	13 (1 Module)	5, 6	POR	QY18U2..B1 *QYD18U2..B1
					10, 15, 16, 20		
					25, 30, 32, 35, 40		
					45, 50, 60		
QY-2(13)-DM-U2-5A-B1 (White Handle)	2	125 Vdc	10	26 (2 Module)	5, 6	POR	QY28U2..B1 *QYD28U2..B1
					10, 15, 16, 20		
					25, 30, 32, 35, 40		
QY-2(13)-DM-U2-080A-B1-ZL (White Handle) ¹	2 (Parallel)	125 Vdc	10	26 (2 Module)	80	POR	QY28U2...B1ZL *QYD28U2...B1ZL
					100		
QY-3(13)-DM-U2-080A-B1-ZL (White Handle) ¹	3 (Parallel)	125 Vdc	10	39 (3 Module)	125	POR	QY38U2...B1ZL *QYD38U2...B1ZL
					150		

QY Range: 250 Vdc Circuit Breakers, 10 kA, Curve U2, Dual Mount and DIN Rail Mount **K6**

Type	Poles	Voltage	kA	MCB Width (mm)	Rating (A)	Price Ea. excl. VAT	Order No.
QY-2(13)-DM-U2-5A-B3-T (White Handle)	2 (Series)	250 Vdc	10	26 (2 Module)	5	POR	QY28U2..B3T *QYD28U2..B3T
					10, 15, 20		
					25, 30, 35, 40		
					45, 50		

Accessories

1	Auxiliary Switch	POR
2	Trip Alarm Switch	
3	1 Auxiliary Switch + Trip Alarm	

Notes:

POR - Price on Request.
Auxiliary switch modules and trip alarm switch modules priced separately.
Contact CBI for details.
Please contact CBI for Amp Ratings not listed.

Full range's data sheets available on www.cbi-lowvoltage.com.
Standard discounts are not applicable.
* DIN rail option.
1. Do not remove factory-fitted bridge pieces.

Approvals



QZ Series Circuit Breaker for Equipment Hydraulic-Magnetic



Product Type	QZ
Ambient Operating Temperature	-40°C to +85°C
Mounting Options	DIN rail, Dual (DIN & mini rail) mounting, Surface mounting clip
Time Delay Curves	1, 2, 3, 9, OP
Endurance	10 000 operations; 1 500 with current, 8 500 without current (IEC 60947-2 Clause 7.2.4.2)* 6 000 operations with current (UL 1077 Clause 22)*
Dielectric Strength	1 000 - 2 000 Vac for one minute (IEC 60947-2 Clause 8.3.3.3)* 1 000 Vac plus twice the rated voltage for one minute (UL 1077 Clause 23)*
Rated Impulse Withstand Voltage	4 kV (IEC 60947-2)
Weight	102 g per pole, 160 g with auxiliary (unpacked)
Altitude	Certification tests done at altitude ≈ 2 000 metres. Will operate at higher altitudes.
Shock	16 G (IEC 60068-2-27)
Vibration	2 G (IEC 60068-2-6) (sinusoidal wave)
Flammability	I3 - Ignition does not persist at 850°C after glow wire is withdrawn with an oxygen index of ≥ 28
Toxicity	F1 - Smoke index of ≤ 20 which determines the fume class
Pollution Degree	PD2 - Normally only non-conductive pollution occurs. Temporary conductivity caused by condensation is to be expected.

Product Type	Supplementary Protector						
Approvals	UL 1077						
	Tested with series fuse					Tested without series fuse	
Number of Poles	1	1	2	3	3	1	3
Operating Voltages	120 Vac	277 Vac	480 Vac	240 Vac	277/480 Vac	120 Vac	240 Vac
Minimum Current Rating	0.1 A					1 A	
Maximum Current Rating	60 A					50 A	
Specific Ratings (Verify Certification)	0.1, 0.5, 1, 2, 3, 4, 5, 6, 7, 8, 9, 10, 12, 15, 16, 20, 25, 30, 35, 40, 45, 50, 60 A						
Short Circuit Capacity (Ics)	5 kA					5 kA	

Product Type	Circuit Breaker				
Approvals	DIN/EN 60947-2, EAC, CE, UKCA				
Number of Poles	1	2 (1+N)	2	3	4 (3+N)
Operating Voltages	240 Vac		415 Vac		
Minimum Current Rating	5 A				
Maximum Current Rating	50 A				
Specific Ratings (Verify Certification)	5, 6, 7, 8, 9, 10, 12, 15, 16, 20, 25, 30, 35, 40, 45, 50 A				
Ultimate S/C Breaking Capacity (Icu)	3 kA				

Notes:
* Refer to the standard for details
Verify approvals for specific ratings in accordance with the relevant test certificates.

QZ Range: 240/415 Vac Circuit Breakers, 3 kA, Curve 2 & 3, Dual Mount and DIN Rail Mount							K6
Type	Poles	Voltage	kA	MCB Width (mm)	Rating (A)	Price Ea. excl. VAT	Order No.
QZ-1(13)-DM-C2-5A (White Handle)	1	240 Vac	3	13 (1 Module)	5, 6	POR	QZ182.. QZ183..
					10, 15, 16, 20		
					25, 30, 35, 40		
					45, 50		
QZ-2(13)-DM-C2-5A (White Handle)	2	415 Vac	3	26 (2 Modules)	5, 6		QZ282.. QZ283..
					10, 15, 16, 20		
					25, 30, 35, 40, 45, 50		
QZ-3(13)-DM-C2-5A (White Handle)	3	415 Vac	3	39 (3 Modules)	5, 6		QZ382.. QZ383..
					10, 15, 16, 20		
					25, 30, 35, 40, 45, 50		
QZ-N-2(13)-DM-C2-5A (White/Green Handle)	1 + N	240 Vac	3	26 (2 Modules)	5, 6, 10, 15, 16, 20	QZ212.. QZ213..	
					25, 30, 35, 40, 45, 50		
QZ-N-4(13)-DM-C2-5A (White/Green Handle)	3 + N	415 Vac	3	52 (4 Modules)	5, 6, 10, 15, 16, 20	QZ412.. QZ413..	
					25, 30, 35, 40, 45, 50		

QZ Range: 240/415 Vac Circuit Breakers, 3 kA, Curve 1, Dual Mount and DIN Rail Mount							K6
Type	Poles	Voltage	kA	MCB Width (mm)	Rating (A)	Price Ea. excl. VAT	Order No.
QZ-1(13)-DM-C1-5A (Orange Handle)	1	240 Vac	3	13 (1 Module)	5, 6, 10, 15, 16, 20	POR	QZ181..
					25, 30, 35, 40, 45, 50		
QZ-2(13)-DM-C1-5A (Orange Handle)	2	415 Vac	3	26 (2 Modules)	5, 6, 10, 15, 16, 20		QZ281..
					25, 30, 35, 40, 45, 50		
QZ-3(13)-DM-C1-5A (Orange Handle)	3	415 Vac	3	39 (3 Modules)	5, 6, 10, 15, 16, 20		QZ381..
					25, 30, 35, 40, 45, 50		
QZ-N-2(13)-DM-C1-5A (Orange/Green Handle)	1 + N	240 Vac	3	26 (2 Modules)	5, 6, 10, 15, 16, 20		QZ211..
					25, 30, 35, 40, 45, 50		
QZ-N-4(13)-DM-C1-5A (Orange/Green Handle)	3 + N	415 Vac	3	52 (4 Modules)	5, 6, 10, 15, 16, 20		QZ411..
					25, 30, 35, 40, 45, 50		

Accessories		
1	Auxiliary switch	POR

Notes:

POR - Price on Request.
 Auxiliary switch modules priced separately.
 Contact CBI for details.
 Please contact CBI for Amp Ratings not listed.
 Full range's data sheets available on www.cbi-lowvoltage.com.
 Standard discounts are not applicable.
 * DIN rail option available

Approvals



YA-Frame Series Circuit Breaker for Equipment Hydraulic-Magnetic



Product Type	Circuit Breaker YA
Ambient Operating Temperature	-40°C to +85°C
Mounting Options	Dual (DIN and Mini rail), DIN rail mount
Time Delay Curves	I, S, M, L
Endurance	10 000 operations; 1 500 with current, 8 500 without current (IEC 60947-2 Clause 7.2.4.2)* Minimum of 1 000 operations with current (UL 489A Clause 12)*
Dielectric Strength	1 000 - 2 000 Vac for one minute (IEC 60947-2 Clause 8.3.3.3)* 1 000 Vac plus twice the rated voltage for one minute (UL 489A Clause 8)*
Rated Impulse Withstand Voltage	4 kV (IEC 60947-2 Clause 8.3.3.2)*
Weight	110 g per pole
Altitude	Certification tests conducted at altitude ≈ 2 000 metres. Will operate at higher altitudes.
Shock	20 G (IEC 60068-2-27)
Vibration	3 G (IEC 60068-2-6) (sinusoidal wave)
Flammability	I3 - Ignition does not persist at 850°C after glow wire is withdrawn with an oxygen index of ≥ 28
Toxicity	F1 - Smoke index of ≤ 20 which determines the fume class
Pollution Degree	PD2 - Normally only non-conductive pollution occurs. Temporary conductivity caused by condensation is to be expected.

Product Type	Circuit Breaker YA, Polarised Product		
Approvals	IEC 60947-2, GB 14048.2, CE, UKCA, AS/NZS 60947-2		
Number of Poles	1 Pole	2 Pole	4 (2 pole in series + 2 pole in series)
Operating Voltages & Interrupting Capacity	300 Vdc @ 6 kA	300 Vdc @ 6 kA 600 Vdc @ 6 kA (series)	400 Vdc @ 6 kA
Minimum Current Rating	0.5 A	0.5 A	0.5 A
Maximum Current Rating	50 A	50 A	32 A

Product Type	Circuit Breaker YA, Polarised Product		
Approvals	UL 489A, CSA C22.2 No. 5-16		
Number of Poles	1 & 2 Poles	2 Pole in series	4 (2 Pole in series + 2 Pole in series)
Operating Voltages & Interrupting Capacity	300 Vdc @ 10 kA	600 Vdc @ 5 kA	400 Vdc @ 10 kA
Minimum Current Rating	0.5 A	0.5 A	0.5 A
Maximum Current Rating	50 A	50 A	32 A

Notes:

* Refer to the standard for details
Verify approvals for specific ratings in accordance with the relevant test certificates.

YA-Frame: 300 Vdc DC Circuit Breakers, 6 kA, Curve M, Dual Mount 57 mm Escutcheon **K6**

Type	Poles	Rating (A)	Price Ea. excl. VAT	BOM Number
YAK-1(13) 300 Vdc	1	3 A - 50 A	POR	YAK1M0__B03
YAK-2(13) 300 Vdc	2	3 A - 50 A		YAK2M0__B03

YA-Frame: 300 Vdc DC Circuit Breakers, 6 kA, Curve M, DIN Rail Mount 45 mm Escutcheon **K6**

Type	Poles	Rating (A)	Price Ea. excl. VAT	BOM Number
YAD-1(13) 300 Vdc	1	3 A - 50 A	POR	YAD1M0__B03
YAD-2(13) 300 Vdc	2	3 A - 50 A		YAD2M0__B03

YA-Frame: 400 Vdc DC Circuit Breakers, 6 kA, Curve M, Dual Mount 57 mm Escutcheon **K6**

Type	Poles	Rating (A)	Price Ea. excl. VAT	BOM Number
YAK-4(13) 400 Vdc	2+2 (Series)	1 A - 32 A	POR	YAK4M0__BT4

YA-Frame: 400 Vdc DC Circuit Breakers, 6 kA, Curve M, DIN Rail Mount 45 mm Escutcheon* **K6**

Type	Poles	Rating (A)	Price Ea. excl. VAT	BOM Number
YAD-4(13) 400 Vdc	2+2 (Series)	1 A - 32 A	POR	YAD4M0__BT4

YA-Frame: 600 Vdc DC Circuit Breakers, 6 kA, Curve M, Dual Mount 57 mm Escutcheon **K6**

Type	Poles	Rating (A)	Price Ea. excl. VAT	BOM Number
YAK-2(13) 600 Vdc	2 (Series)	3 A - 50 A	POR	YAK2M0__BT6

YA-Frame: 600 Vdc DC Circuit Breakers, 6 kA, Curve M, DIN Rail Mount 45 mm Escutcheon* **K6**

Type	Poles	Rating (A)	Price Ea. excl. VAT	BOM Number
YAD-2(13) 600 Vdc	2 (Series)	3 A - 50 A	POR	YAD2M0__BT6

Accessories				
1	Auxiliary switch			POR

Notes:

POR - Price on Request.
 Auxiliary switch modules priced separately.
 Contact CBI for details.
 Please contact CBI for Amp Ratings not listed.
 Full range's data sheets available on www.cbi-lowvoltage.com.
 Refer to data sheet for product wiring diagram.
 Standard discounts are not applicable.
 * DIN rail option.
 Do not remove factory-fitted bridge pieces.

Approvals



Surge Protection Devices



QFL-2(13)



QFL-4(13)



QKL-2(13)D



QKL-4(13)D

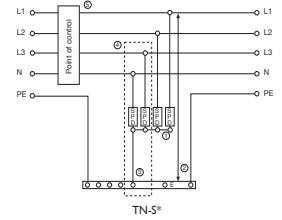
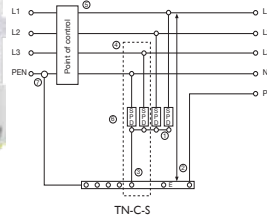

**Clip-in Dual Mounted Surge Protection Devices
Imax 10 kA (8 / 20 μs) Surge Protection Devices: 275 V Mini Rail (57 mm Escutcheon) - Class II ¹** **H2**

Product	Description	Width	Std. Pack	Price Ea. excl. VAT	Order No.
QFL-1(13)	1 pole 275 V, with indication	13 mm	12	R 309.00	QFLM0001
QFLN-2(13)	1 pole and neutral 275 V, with indication	26 mm	6	R 585.00	QFLM0002
QFL-3(13)	3 pole 275 V, with indication	39 mm	4	R 876.00	QFLM0003
QFLN-4(13)	3 pole and neutral 275 V, with indication	52 mm	3	R 1 168.00	QFLM0004

Imax 40 kA (8 / 20 μs) Surge Protection Devices: 275 V Mini Rail (57 mm Escutcheon) - Class II ² **H2**

Product	Description	Width	Std. Pack	Price Ea. excl. VAT	Order No.
QKL-1(13)	1 pole 275 V, with indication	13 mm	12	R 768.00	QKLM0001
QKLN-2(13)	1 pole and neutral 275 V, with indication	26 mm	6	R 1 470.00	QKLM0002
QKL-3(13)	3 pole 275 V, with indication	39 mm	4	R 2 208.00	QKLM0003
QKLN-4(13)	3 pole and neutral 275 V, with indication	52 mm	3	R 2 941.00	QKLM0004

Imax 10 kA (8 / 20 μs) Surge Protection Devices¹: 275 V DIN Rail (45 mm Escutcheon) - Class II ¹ **H2**

Product	Description	Width	Std. Pack	Price Ea. excl. VAT	Order No.
QFL-1(13)D	1 pole 275 V, with indication	13 mm	12	R 309.00	QFLD0001
QFLN-2(13)D	1 pole and neutral 275 V, with indication	26 mm	6	R 585.00	QFLD0002
QFL-3(13)D	3 pole 275 V, with indication	39 mm	4	R 876.00	QFLD0003
QFLN-4(13)D	3 pole and neutral 275 V, with indication	52 mm	3	R 1 168.00	QFLD0004

Imax 40 kA (8 / 20 μs) Surge Protection Devices: 275 V DIN Rail (45 mm Escutcheon) - Class II ² **H2**

Product	Description	Width	Std. Pack	Price Ea. excl. VAT	Order No.
QKL-1(13)D	1 pole 275 V, with indication	13 mm	12	R 768.00	QKLD0001
QKLN-2(13)D	1 pole and neutral 275 V, with indication	26 mm	6	R 1 470.00	QKLD0002
QKL-3(13)D	3 pole 275 V, with indication	39 mm	4	R 2 208.00	QKLD0003
QKLN-4(13)D	3 pole and neutral 275 V, with indication	52 mm	3	R 2 941.00	QKLD0004

Imax 10 kA (8 / 20 μs) Surge Protection Devices: 130 V Dual Mounted - Class II ¹ **H2**

Product	Description	Width	Std. Pack	Price Ea. excl. VAT	Order No.
QFL-1(13)	1 pole 130 V, 5 kA with indication mini rail (57 escutcheon)	13 mm	12	R 309.00	QFLM1001
QFL-1(13)D	1 pole 130 V, 5 kA with indication DIN rail (45 escutcheon)	13 mm	12	R 321.00	QFLD1001

Notes:

1. Required to be backed up by a QA MCB (QFL)

2. Required to be backed up by a QF MCB (QKL)

Class II SPDs are only to be used where items are not subjected to direct lightning strikes and the voltage / current surges are attenuated (reduced in magnitude)

Product Type	QFL	QKL
Maximum Continuous Operating Voltage (U _c)	275 Vac (RMS)	275 Vac (RMS)
Voltage Protection level (Peak) (U _p)	1.5 kV	1.5 kV
Nominal Discharge Current (Inom) (I _n)	5 kA (8/20 μs)	20 kA (8/20 μs)
Maximum Discharge Current (Imax)	10 kA (8/20 μs)	40 kA (8/20 μs)
Short Circuit Withstand*	2.5 kA (50 Hz)	5 kA (50 Hz)
Lightning Protection Zone	OB to 1 or 1 to 2	OB to 1 or 1 to 2
SPD Class	Class II	Class II

Certification: SANS 61643-1 Class II

QA Range Mini Rail 13 mm Hydraulic-Magnetic



QA-1(13)



QA-2(13)



QA-3(13)



QA-N-4(13)

Circuit Breakers 3 kA Curve 3 (Standard) Mini Rail Mounting, 57 mm Escutcheon								L1
Type	Poles	Voltage	kA	MCB Width (mm)	Std. Pack	Ratings (A)	Price Ea. excl. VAT	Order No.
QA-1(13) (White Handle)	1	240 Vac	3	13 (1 Module)	12	1, 2, 5	R 174.00	QAL183...
						10, 15, 20	R 177.00	
						25, 30, 35, 40	R 198.00	
						45, 50, 60	R 204.00	
QA-2(13) (White Handle)	2	415 Vac	3	26 (2 Modules)	6	1, 2, 5	R 664.00	QAL283...
						10, 15, 20	R 681.00	
						25, 30, 35, 40	R 701.00	
						45, 50	R 754.00	
QA-3(13) (White Handle)	3	415 Vac	3	39 (3 Modules)	4	5	R 980.00	QAL383...
						10, 15, 20	R 1 065.00	
						25, 30, 35	R 1 081.00	
						40, 45, 50	R 1 102.00	
QA-N-2(13) (White/Green Handle)	1 + N	240 Vac	3	26 (2 Modules)	6	1, 2, 5, 10, 15, 20	R 469.00	QAL213...
						25, 30, 35, 40, 45, 50	R 497.00	
						60	R 506.00	
QA-N-4(13) (White/Green Handle)	3 + N	415 Vac	3	52 (4 Modules)	3	5, 10, 20, 25	R 1 274.00	QAL413...
						30, 35, 40, 45, 50	R 1 303.00	

Switch Disconnectors 3 kA, Mini Rail Mounting 57 mm Escutcheon								L1
Type	Poles	Voltage	Withstand kA ¹	MCB Width (mm)	Std. Pack	Ratings (A)	Price Ea. excl. VAT	Order No.
QA-S-1(13) (Green Handle)	1	240 Vac	3	13 (1 Module)	12	63	R 172.00	QAL10063
QA-S-2(13) (Green Handle)	2	415 Vac	3	26 (2 Modules)	6	63	R 344.00	QAL20063
QA-S-3(13) (Green Handle)	3	415 Vac	3	39 (3 Modules)	4	63	R 530.00	QAL30063
QA-S-4(13) (Green Handle)	4	415 Vac	3	52 (4 Modules)	3	63	R 667.00	QAL40063

Notes:

Max cable size 25 mm²

The above Voltages and kA ratings are in accordance with SANS specifications (see side of product)

The front printing on the product refers to Voltages and kA ratings in accordance with IEC specifications

1. Required to be backed up by a suitable Short Circuit Protection Device (SCPD)

Please contact CBI for Amp Ratings not listed



QAC Single Phase Changeover Switch Range Dual Mount and Dual Escutcheon



QAC-4(13)

Changeover Switch 3 kA, Mini Rail and DIN Rail Mounting 57 mm and 45 mm Escutcheon								AB
Type	Modules	Voltage	Withstand kA	MCB Width (mm)	Std. Pack	Ratings (A)	Price Ea. excl. VAT	Order No.
QA single phase changeover switch	4	240 Vac	3	52 mm (4 modules)	1	63 A	R 508.00	QAC40063

Notes:

Max cable size 25 mm²

The front printing on the product refers to Voltages and kA ratings in accordance with IEC specifications
For single phase installations only

QIL Indicator Light Range Mini and DIN Mount



QIL-1(13)



QIL-2(13)



QIL-1(13)D



QIL-2(13)D

Indicator Light, Mini Rail Mounting 57 mm Escutcheon							AB
Type	Modules	Voltage	Width (mm)	Std. Pack	Price Ea. excl. VAT	Order No.	
QIL-1(13) (Red indicator)	1	240 Vac	13 mm (1 module)	12	R 62.00	QILM0001	
QIL-1(13) (Green indicator)	1	240 Vac	13 mm (1 module)	12	R 62.00	QILM0101	
QIL-2(13) (Live 1 red indicator, Live 2 green indicator)	2	240 Vac	26 mm (2 module)	12	R 114.00	QILM0002	
Indicator Light, DIN Rail Mounting 45 mm Escutcheon							AB
QIL-1(13)D (Red indicator)	1	240 Vac	13 mm (1 module)	12	R 62.00	QILD0001	
QIL-1(13)D (Green indicator)	1	240 Vac	13 mm (1 module)	12	R 62.00	QILD0101	
QIL-2(13)D (Live 1 red indicator, Live 2 green indicator)	2	240 Vac	26 mm (2 module)	12	R 114.00	QILD0002	

QA Range DIN Rail 13 mm Hydraulic-Magnetic



QA-1(13)-D



QA-2(13)-D



QA-N-4(13)-D

Circuit Breakers 3 kA Curve 3 (Standard) DIN Rail Mounting, 45 mm Escutcheon								L1
Type	Poles	Voltage	kA	MCB Width (mm)	Std. Pack	Ratings (A)	Price Ea. excl. VAT	Order No.
QA-1(13)-D (White Handle)	1	240 Vac	3	13 (1 Module)	12	1, 2, 5	R 174.00	QAD183...
						10, 15, 20	R 177.00	
						25, 30, 35, 40	R 198.00	
						45, 50, 60	R 204.00	
QA-2(13)-D (White Handle)	2	415 Vac	3	26 (2 Modules)	6	1, 2, 5	R 664.00	QAD283...
						10, 15, 20	R 681.00	
						25, 30, 35, 40	R 701.00	
						45, 50	R 754.00	
QA-3(13)-D (White Handle)	3	415 Vac	3	39 (3 Modules)	4	5	R 980.00	QAD383...
						10, 15, 20	R 1 065.00	
						25, 30, 35	R 1 081.00	
						40, 45, 50	R 1 102.00	
QA-N-2(13)-D (White/Green Handle)	1 + N	240 Vac	3	26 (2 Modules)	6	1, 2, 5, 10, 15, 20	R 469.00	QAD213...
						25, 30, 35, 40, 45, 50	R 497.00	
						60	R 506.00	
QA-N-4(13)-D (White/Green Handle)	3 + N	415 Vac	3	52 (4 Modules)	3	5, 10, 20, 25	R 1 274.00	QAD413...
						30, 35, 40, 45, 50	R 1 303.00	

Switch Disconnectors 3 kA, DIN Rail Mounting 45 mm Escutcheon								L1
Type	Poles	Voltage	Withstand kA ¹	MCB Width (mm)	Std. Pack	Ratings (A)	Price Ea. excl. VAT	Order No.
QA-S-1(13)-D (Green Handle)	1	240 Vac	3	13 (1 Module)	12	63	R 172.00	QAD10063
QA-S-2(13)-D (Green Handle)	2	415 Vac	3	26 (2 Modules)	6	63	R 344.00	QAD20063
QA-S-3(13)-D (Green Handle)	3	415 Vac	3	39 (3 Modules)	4	63	R 530.00	QAD30063
QA-S-4(13)-D (Green Handle)	4	415 Vac	3	52 (4 Modules)	3	63	R 667.00	QAD40063

Notes:

Max cable size 25 mm²

The above Voltages and kA ratings are in accordance with SANS specifications (see side of product)

The front printing on the product refers to Voltages and kA ratings in accordance with IEC specifications

1. Required to be backed up by a suitable Short Circuit Protection Device (SCPD)

Please contact CBI for Amp Ratings not listed



QF Range Dual Mount 13 mm Hydraulic-Magnetic



Circuit Breakers 6 kA Curve 1 (Special) Mini and DIN Rail Mounting, 57 mm Escutcheon L2

Type	Poles	Voltage	kA	MCB Width (mm)	Std. Pack	Ratings (A)	Price Ea. excl. VAT	Order No.
QF-1(13) (Orange Handle)	1	240 Vac	6	13 (1 Module)	12	5, 10, 15, 20, 25	R 264.00	QFA181...
QF-2(13) (Orange Handle)	2	415 Vac	6	26 (2 Modules)	6	15, 20	R 974.00	QFA281...
QF-3(13) (Orange Handle)	3	415 Vac	6	39 (3 Modules)	4	5, 10, 15, 20	R 1 461.00	QFA381...
						25	R 1 471.00	
QF-N-2(13) (Orange/Green Handle)	1 + N	240 Vac	6	26 (2 Modules)	6	5, 10, 15, 20	R 559.00	QFA211...
						25	R 565.00	

Circuit Breakers 6 kA Curve 2 (Standard) Mini and DIN Rail Mounting, 57 mm Escutcheon L2

Type	Poles	Voltage	kA	MCB Width (mm)	Std. Pack	Ratings (A)	Price Ea. excl. VAT	Order No.
QF-1(13) (White Handle)	1	240 Vac	6	13 (1 Module)	12	1, 2	R 275.00	QFA182...
						5	R 188.00	
						10, 15, 20	R 192.00	
						25	R 214.00	
QF-2(13) (White Handle)	2	415 Vac	6	26 (2 Modules)	6	5	R 711.00	QFA282...
						10, 15, 20	R 731.00	
						25	R 796.00	
QF-3(13) (White Handle)	3	415 Vac	6	39 (3 Modules)	4	5	R 1 140.00	QFA382...
						10, 15, 20	R 1 140.00	
						25	R 1 159.00	
QF-N-2(13) (White/Green Handle)	1 + N	240 Vac	6	26 (2 Modules)	6	5, 10, 15, 20	R 502.00	QFA212...
						25	R 534.00	
QF-N-4(13) (White/Green Handle)	3 + N	415 Vac	6	52 (4 Modules)	3	5, 10, 15, 20, 25	R 1 366.00	QFA412...

Notes:

Max cable Size 25 mm²

The above Voltages and kA ratings are in accordance with SANS specifications (see side of product).

The front printing on the product refers to Voltages and kA ratings in accordance with IEC specifications.

1. Required to be backed up by a suitable Short Circuit Protection Device (SCPD)

Please contact CBI for Amp ratings not listed



QF Range Dual Mount 13 mm Hydraulic-Magnetic

Switch Disconnectors 6 kA, Mini and DIN Rail Mounting, 57 mm Escutcheon								L2
Type	Poles	Voltage	Withstand kA ¹	MCB Width (mm)	Std. Pack	Ratings (A)	Price Ea. excl. VAT	Order No.
QF-S-1(13) (Green Handle)	1	240 Vac	6	13 (1 Module)	12	63	R 196.00	QFA10063
QF-S-2(13) (Green Handle)	2	415 Vac	6	26 (2 Modules)	6	63	R 369.00	QFA20063
QF-S-3(13) (Green Handle)	3	415 Vac	6	39 (3 Modules)	4	63	R 576.00	QFA30063
QF-S-4(13) (Green Handle)	4	415 Vac	6	52 (4 Modules)	3	63	R 739.00	QFA40063

Notes:

Max cable size 25 mm² - QF(13)

The above Voltages and kA ratings are in accordance with SANS specifications (see side of product).

The front printing on the product refers to Voltages and kA ratings in accordance with IEC specifications.

1. Required to be backed up by a suitable Short Circuit Protection Device (SCPD).



QF Range DIN Mount 13 mm Hydraulic-Magnetic



QF-1(13)-D C1



QF-3(13)-D C1



QF-1(13)-D C2



QF-2(13)-D C2



QF-N-4(13)-D C2

Circuit Breakers 6 kA Curve 1 (Special) DIN Rail Mounting, 45 mm Escutcheon

L2

Type	Poles	Voltage	kA	MCB Width (mm)	Std. Pack	Ratings (A)	Price Ea. excl. VAT	Order No.
QF-1(13)-D (Orange Handle)	1	240 Vac	6	13 (1 Module)	12	5, 10, 15, 20, 25	R 264.00	QFB181...
QF-2(13)-D (Orange Handle)	2	415 Vac	6	26 (2 Modules)	6	15, 20	R 974.00	QFB281...
QF-3(13)-D (Orange Handle)	3	415 Vac	6	39 (3 Modules)	4	5, 10, 15, 20	R 1 461.00	QFB381...
						25	R 1 471.00	
QF-N-2(13)-D (Orange/Green Handle)	1 + N	240 Vac	6	26 (2 Modules)	6	5, 10, 15, 20	R 559.00	QFB211...
						25	R 565.00	

Circuit Breakers 6 kA Curve 2 (Standard) DIN Rail Mounting, 45 mm Escutcheon

L2

Type	Poles	Voltage	kA	MCB Width (mm)	Std. Pack	Ratings (A)	Price Ea. excl. VAT	Order No.
QF-1(13)-D (White Handle)	1	240 Vac	6	13 (1 Module)	12	1, 2	R 275.00	QFB182...
						5	R 188.00	
						10, 15, 20	R 192.00	
						25	R 214.00	
QF-2(13)-D (White Handle)	2	415 Vac	6	26 (2 Modules)	6	5	R 711.00	QFB282...
						10, 15, 20	R 731.00	
						25	R 796.00	
QF-3(13)-D (White Handle)	3	415 Vac	6	39 (3 Modules)	4	5	R 1 140.00	QFB382...
						10, 15, 20	R 1 140.00	
						25	R 1 159.00	
QF-N-2(13)-D (White/Green Handle)	1 + N	240 Vac	6	26 (2 Modules)	6	5, 10, 15, 20	R 502.00	QFB212...
						25	R 534.00	
QF-N-4(13)-D (White/Green Handle)	3 + N	415 Vac	6	52 (4 Modules)	3	5, 10, 15, 20, 25	R 1 366.00	QFB412...

Notes:

Max cable Size 25 mm²

The above Voltages and kA ratings are in accordance with SANS specifications (see side of product).

The front printing on the product refers to Voltages and kA ratings in accordance with IEC specifications.

1. Required to be backed up by a suitable Short Circuit Protection Device (SCPD)

Please contact CBi for Amp ratings not listed



QF Range DIN Mount 13 mm Hydraulic-Magnetic

Switch Disconnectors 6 kA, DIN Rail Mounting, 45 mm Escutcheon								L2
Type	Poles	Voltage	Withstand kA ¹	MCB Width (mm)	Std. Pack	Ratings (A)	Price Ea. excl. VAT	Order No.
QF-S-1(13)-D (Green Handle)	1	240 Vac	6	13 (1 Module)	12	63	R 196.00	QFB10063
QF-S-2(13)-D (Green Handle)	2	415 Vac	6	26 (2 Modules)	6	63	R 369.00	QFB20063
QF-S-3(13)-D (Green Handle)	3	415 Vac	6	39 (3 Modules)	4	63	R 576.00	QFB30063
QF-S-4(13)-D (Green Handle)	4	415 Vac	6	52 (4 Modules)	3	63	R 739.00	QFB40063

Notes:

Max cable size 25 mm² - QF(13)D

The above Voltages and kA ratings are in accordance with SANS specifications (see side of product).

The front printing on the product refers to Voltages and kA ratings in accordance with IEC specifications.

1. Required to be backed up by a suitable Short Circuit Protection Device (SCPD).



QF Range Dual Mount Low Rating 26 mm Hydraulic-Magnetic



QF-1(26)



QF-2(26)



QF-N-4(26)

Circuit Breakers 6 kA Curve 1 (Special) Mini and DIN Rail Mounting, 57 mm Escutcheon								L2
Type	Poles	Voltage	kA	MCB Width (mm)	Std. Pack	Ratings (A)	Price Ea. excl. VAT	Order No.
QF-1(26) (Orange Handle)	1	240 Vac	6	26 (1 Module)	12	5, 10, 15, 20	R 268.00	QFE181...
						25, 30, 35, 40, 45, 50, 63	R 275.00	
QF-2(26) (Orange Handle)	2	415 Vac	6	52 (2 Modules)	6	10, 20	R 982.00	QFE281...
						25, 30, 40, 50, 63	R 986.00	
QF-3(26) (Orange Handle)	3	415 Vac	6	78 (3 Modules)	4	5	R 1 469.00	QFE381...
						10, 15, 20	R 1 472.00	
						25, 30, 35, 40, 45, 50, 63	R 1 475.00	

Circuit Breakers 6 kA Curve 2 (Standard) Mini and DIN Rail Mounting, 57 mm Escutcheon								L2
Type	Poles	Voltage	kA	MCB Width (mm)	Std. Pack	Ratings (A)	Price Ea. excl. VAT	Order No.
QF-1(26) (White Handle)	1	240 Vac	6	26 (1 Module)	12	1, 2	R 290.00	QFE182...
						5, 10	R 182.00	
						15, 20, 25, 30	R 195.00	
						35, 40, 45, 50, 63	R 206.00	
QF-2(26) (White Handle)	2	415 Vac	6	52 (2 Modules)	6	5	R 719.00	QFE282...
						10, 15, 20	R 731.00	
						25, 30, 35, 40	R 806.00	
						45, 50, 63	R 817.00	
QF-3(26) (White Handle)	3	415 Vac	6	78 (3 Modules)	4	5, 10, 15, 20	R 1 050.00	QFE382...
						25, 30, 35, 40, 45, 50, 63	R 1 059.00	
QF-N-2(26) (White/ Green Handle)	1 + N	240 Vac	6	52 (2 Modules)	6	5, 10, 15, 20	R 484.00	QFE212...
						25, 30, 35, 40	R 505.00	
						45, 50, 63	R 564.00	
QF-N-4(26) (White/ Green Handle)	3 + N	415 Vac	6	104 (4 Modules)	3	5	R 1 154.00	QFE412...
						10, 20	R 1 368.00	
						25, 30, 35	R 1 449.00	
						40	R 1 469.00	
						45, 50, 63	R 1 589.00	

Notes:

1. Required to be backed up by a suitable Short Circuit Protection Device (SCPD).
Max cable size up to 50 mm²



QF Range Dual Mount High Rating 26 mm Hydraulic-Magnetic



QF-1(26)



QF-2(26)



QF-3(26)



QF-N-4(26)

Circuit Breakers 6 kA Curve 1 (Special) Mini and DIN Rail Mounting, 57 mm Escutcheon L2

Type	Poles	Voltage	kA	MCB Width (mm)	Std. Pack	Ratings (A)	Price Ea. excl. VAT	Order No.
QF-1(26) (Orange Handle)	1	240 Vac	6	26 (1 Module)	12	70, 80	R 443.00	QFE181...
						90, 100, 125	R 635.00	
QF-2(26) (Orange Handle)	2	415 Vac	6	52 (2 Modules)	6	70, 80	R 1 434.00	QFE281...
						90, 100, 125	R 1 561.00	
QF-3(26) (Orange Handle)	3	415 Vac	6	78 (3 Modules)	4	70, 80	R 2 155.00	QFE381...
						90, 100, 125	R 2 447.00	

Circuit Breakers Curve 1 (Special) 6 kA, Dual Mounting, 57 mm Escutcheon L2

Type	Poles	Voltage	kA	MCB Width (mm)	Std. Pack	Ratings (A)	Price Ea. excl. VAT	Order No.
QF-N-2 (26)-DM (Orange/Green Handle)*	2	240 Vac	6	26 (2 Modules)	12	63	R 679.00	QFE21163
						100	R 756.00	QFE211100
						125	R 756.00	QFE211125

Circuit Breakers 6 kA Curve 2 (Standard) Mini and DIN Rail Mounting, 57 mm Escutcheon L2

Type	Poles	Voltage	kA	MCB Width (mm)	Std. Pack	Ratings (A)	Price Ea. excl. VAT	Order No.
QF-1(26) (White Handle)	1	240 Vac	6	26 (1 Module)	12	70, 80	R 388.00	QFE182...
						90, 100, 125	R 450.00	
QF-2(26) (White Handle)	2	415 Vac	6	52 (2 Modules)	6	70, 80	R 1 350.00	QFE282...
						90, 100, 125	R 1 470.00	
QF-3(26) (White Handle)	3	415 Vac	6	78 (3 Modules)	4	70, 80	R 1 942.00	QFE382...
						90, 100, 125	R 2 330.00	
QF-N-2(26) (White/Green Handle)	1 + N	240 Vac	6	52 (2 Modules)	6	70, 80	R 844.00	QFE212...
						90, 100, 125	R 853.00	
QF-N-4(26) (White/Green Handle)	3 + N	415 Vac	6	104 (4 Modules)	6	70, 80	R 2 740.00	QFE412...
						90, 100, 125		

Switch Disconnectors 6 kA, Mini and DIN Rail Mounting, 57 mm Escutcheon L2

Type	Poles	Voltage	Withstand kA ¹	MCB Width (mm)	Std. Pack	Ratings (A)	Price Ea. excl. VAT	Order No.
QF-S-1(26) (Green Handle)	1	240 Vac	6	26 (1 Module)	12	63	R 218.00	QFE10063
						100, 125	R 369.00	QFE100...
QF-S-2(26) (Green Handle)	2	415 Vac	6	52 (2 Modules)	6	63	R 431.00	QFE20063
						100, 125	R 708.00	QFE200...
QF-S-3(26) (Green Handle)	3	415 Vac	6	78 (3 Modules)	4	63	R 670.00	QFE30063
						100, 125	R 1 170.00	QFE300...
QF-S-4(26) (Green Handle)	4	415 Vac	6	104 (4 Modules)	3	63	R 838.00	QFE40063
						100, 125	R 1 560.00	QFE400...

Notes:

Max cable size up to 50 mm²

1. Required to be backed up by a suitable Short Circuit Protection Device (SCPD).



QF Range DIN Rail 18 mm Hydraulic-Magnetic

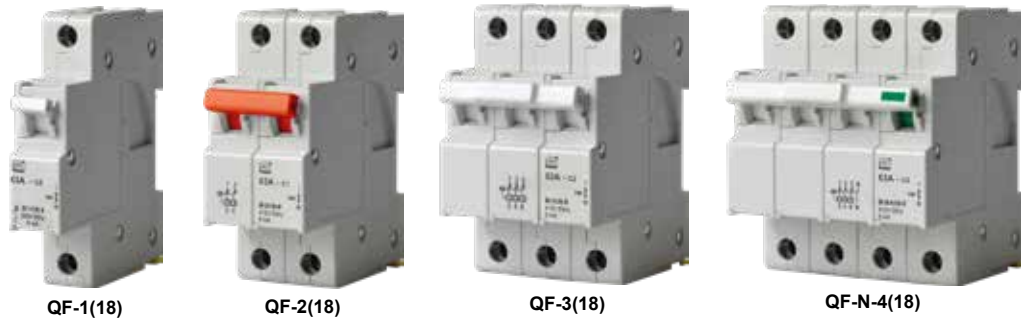

Circuit Breakers 6 kA Curve 1 (Special) DIN Rail Mounting, 45 mm Escutcheon								L2
Type	Poles	Voltage	kA	MCB Width (mm)	Std. Pack	Ratings (A)	Price Ea. excl. VAT	Order No.
QF-1(18)-D (Orange Handle)	1	240 Vac	6	18 (1 Module)	12	6, 10, 16, 20	R 266.00	QFD181...
						25, 32, 40, 50, 63	R 274.00	
QF-2(18)-D (Orange Handle)	2	415 Vac	6	36 (2 Modules)	6	6, 10, 16, 20	R 982.00	QFD281...
						25, 32, 40, 50, 63	R 985.00	
QF-3(18)-D (Orange Handle)	3	415 Vac	6	54 (3 Modules)	4	6, 10, 16, 20	R 1 471.00	QFD381...
						25, 32, 40, 50, 63	R 1 475.00	

Circuit Breakers 6 kA Curve 2 (Standard) DIN Rail Mounting, 45 mm Escutcheon								L2
Type	Poles	Voltage	kA	MCB Width (mm)	Std. Pack	Ratings (A)	Price Ea. excl. VAT	Order No.
QF-1(18)-D (White Handle)	1	240 Vac	6	18 (1 Module)	12	1, 2	R 290.00	QFD182...
						6, 10, 16, 20	R 184.00	
						25, 32	R 207.00	
						35, 40, 50, 63	R 212.00	
QF-2(18)-D (White Handle)	2	415 Vac	6	36 (2 Modules)	6	6	R 719.00	QFD282...
						10, 16, 20	R 731.00	
						25, 32, 40	R 807.00	
QF-3(18)-D (White Handle)	3	415 Vac	6	54 (3 Modules)	4	6	R 1 057.00	QFD382...
						10, 16, 20	R 1 050.00	
						25, 32, 40, 45, 50, 63	R 1 059.00	
QF-N-2(18)-D (White / Green Handle)	1 + N	240 Vac	6	36 (2 Modules)	6	6, 10, 16, 20	R 489.00	QFD212...
						25, 32, 40	R 508.00	
						45, 50, 63	R 568.00	
QF-N-4(18)-D (White / Green Handle)	3 + N	415 Vac	6	72 (4 Modules)	3	10, 20	R 1 367.00	QFD412...
						25, 32, 40	R 1 447.00	
						50, 63	R 1 466.00	

Switch Disconnectors 6 kA, DIN Rail Mounting, 45 mm Escutcheon								L2
Type	Poles	Voltage	Withstand kA ¹	MCB Width (mm)	Std. Pack	Ratings (A)	Price Ea. excl. VAT	Order No.
QF-S-1(18) (Green Handle)	1	240 Vac	6	18 (1 Module)	12	63	R 218.00	QFD10063SI
QF-S-2(18) (Green Handle)	2	415 Vac	6	36 (2 Modules)	6	63	R 431.00	QFD20063SI
QF-S-3(18) (Green Handle)	3	415 Vac	6	54 (3 Modules)	4	63	R 669.00	QFD30063SI
QF-S-4(18) (Green Handle)	4	415 Vac	6	72 (4 Modules)	3	63	R 814.00	QFD40063SI

Notes:

Max cable size up to 35 mm²

The above Voltages and kA ratings are in accordance with SANS specification (see side of product).

The front printing on the product refers to Voltages and kA ratings in accordance with IEC specifications.

Use curve 1 for motor protection.



QF Range DIN Rail Hydraulic-Magnetic Earth Leakages (30 mA)



QF14AD



QF14CD

DIN Rail Mount									
Type	Poles	Voltage	kA	mA	Width (mm)	Std. Pack	Rating (A)	Price Ea. excl. VAT	Order No.
DIN Commercial / Industrial Earth Leakage Protection Device Single Phase with Overload Protection (DIN Mount)									L2
QF14AD	1 + N	240 Vac	6	30	36	10	6, 10, 16, 20, 32, 40, 50, 63	R 2 135.00	QF14AD2...
DIN Commercial / Industrial Earth Leakage Protection Device Single Phase without Overload Protection (DIN Mount)									L2
QF14CD ¹	1 + N	240 Vac	6	30	36	10	63	R 1 474.00	QF14CD63



QA, QF & SF Range Earth Leakages - Hydraulic-Magnetic



QA17A

QF17C

QA36AW

SF15A

1. Special Earth Leakage Protection Devices

All products manufactured by CBI to meet special non-standard requirements of customers will be quoted for (Price On Request).

2. Standard Current Ratings

Ampere ratings indicated are standard. Non-standard ratings can be provided (POR).

3. Earth Leakage Protection Devices Sensitivities

Sensitivities indicated are standard. Non-standard sensitivities can be provided (POR).

Earth Leakage Protection Devices Abbreviation Codes

Suffix A

Earth Leakage protection device with overload, Single pole and Neutral / 3 pole and Neutral versions.

Suffix C

Earth Leakage protection device (switch disconnecter, non overload), single pole and 3 pole versions.

Dual and Mini Rail Mount									
Type	Poles	Voltage	kA	mA	Width (mm)	Std. Pack	Rating (A)	Price Ea. excl. VAT	Order No.
Residential / Commercial Earth Leakage Protection Device Single Phase with Overload Protection (Dual Mount)									
QA17A	1 + N	240 Vac	3	30	26	10	5, 10, 15, 20, 25, 30, 40, 50, 63	R 1 978.00	QA17A...
Residential / Commercial Earth Leakage Protection Device Single Phase without Overload Protection (Dual Mount)									
QA17C ¹	1 + N	240 Vac	3	30	26	10	63	R 1 028.00	QA17C63
Commercial / Industrial Earth Leakage Protection Device Single Phase with Overload Protection (Dual Mount)									
QF17A	1 + N	240 Vac	6	30	26	10	5, 10, 15, 20, 25, 30, 40, 50, 63	R 2 135.00	QF17A...
Commercial / Industrial Earth Leakage Protection Device Single Phase without Overload Protection (Dual Mount)¹									
QF17C ¹	1 + N	240 Vac	6	30	26	10	63	R 1 474.00	QF17C63
Residential / Commercial Earth Leakage Protection Device Three Phase with Overload Protection (Dual Mount)									
QA36AW	3 + N	415 Vac	3	30	78	5	6, 10, 15, 20, 25, 30, 40, 50, 63	R 3 481.00	QA36AW2...
Residential / Commercial Earth Leakage Protection Device Three Phase without Overload Protection (Dual Mount)¹									
QA36CW	3 + N	415 Vac	3	30	78	5	63	R 2 251.00	QA36CW63
Commercial / Industrial Earth Leakage Protection Device Single Phase with Overload Protection (Mini Rail)									
SF15A	1 + N	240 Vac	6	30	65	10	80, 100	R 3 006.00	SF15K...
Commercial / Industrial Earth Leakage Protection Device Single Phase without Overload Protection (Mini Rail)¹									
SF15C ¹	1 + N	240 Vac	6	30	65	10	100	R 2 056.00	SF15A99
Commercial / Industrial Earth Leakage Protection Device Three Phase with Overload Protection (Mini Rail)									
SF36A	3 + N	415 Vac	6	30	117	5	15, 20, 30, 40, 50, 60, 70, 80	R 3 956.00	SF35K...
Commercial / Industrial Earth Leakage Protection Device Three Phase without Overload Protection (Mini Rail)¹									
SF36C ¹	3 + N	415 Vac	6	30	117	5	80	R 3 323.00	SF35A80

Note:

- Required to be backed by suitable Short Circuit Protection Device (SCPD).



SM Range Earth Leakages



SM15



SM36

110 Vac Mining/Industrial Earth Leakage Protection Device, Single Phase with Overload Protection (Mini Rail)									L2
Type	Poles	Voltage	kA	mA	Width (mm)	Std. Pack	Rating (A)	Price Ea. excl. VAT	Order No.
SM15A	1 + N	110 Vac	6	30 mA	65	10	10, 15, 20, 30, 40, 50, 60, 80, 100	R 3 006.00	SN15K...
SM15A	1 + N	110 Vac	6	50 mA	65	10	10, 15, 20, 30, 40, 50, 60, 80, 100	R 3 006.00	SN15L...
SM15A	1 + N	110 Vac	6	100 mA	65	10	10, 15, 20, 30, 40, 50, 60, 80, 100	R 3 006.00	SN15M...
SM15A	1 + N	110 Vac	6	250 mA	65	10	10, 15, 20, 30, 40, 50, 60, 80, 100	R 3 006.00	SN15N...
SM15A	1 + N	110 Vac	6	375 mA	65	10	10, 15, 20, 30, 40, 50, 60, 80, 100	R 3 006.00	SN15P...
SM15A	1 + N	110 Vac	6	500 mA	65	10	10, 15, 20, 30, 40, 50, 60, 80, 100	R 3 006.00	SN15Q...
SM15A	1 + N	110 Vac	6	1000 mA	65	10	10, 15, 20, 30, 40, 50, 60, 80, 100	R 3 006.00	SN15R...
240 Vac Mining / Industrial Earth Leakage Protection Device, Single Phase with Overload Protection (Mini Rail)									L2
Type	Poles	Voltage	kA	mA	Width (mm)	Std. Pack	Rating (A)	Price Ea. excl. VAT	Order No.
SM15A	1 + N	240 Vac	6	50 mA	65	10	10, 15, 20, 30, 40, 50, 60, 80, 100	R 3 006.00	SM15L...
SM15A	1 + N	240 Vac	6	100 mA	65	10	10, 15, 20, 30, 40, 50, 60, 80, 100	R 3 006.00	SM15M...
SM15A	1 + N	240 Vac	6	250 mA	65	10	10, 15, 20, 30, 40, 50, 60, 80, 100	R 3 006.00	SM15N...
SM15A	1 + N	240 Vac	6	375 mA	65	10	10, 15, 20, 30, 40, 50, 60, 80, 100	R 3 006.00	SM15P...
SM15A	1 + N	240 Vac	6	500 mA	65	10	10, 15, 20, 30, 40, 50, 60, 80, 100	R 3 006.00	SM15Q...
SM15A	1 + N	240 Vac	6	1000 mA	65	10	10, 15, 20, 30, 40, 50, 60, 80, 100	R 3 006.00	SM15R...
110 Vac Mining / Industrial Earth Leakage Protection Device, Three Phase with Overload Protection (Mini Rail)									L2
Type	Poles	Voltage	kA	mA	Width (mm)	Std. Pack	Rating (A)	Price Ea. excl. VAT	Order No.
SM36A	3 + N	110 Vac	6	30 mA	117	5	10, 15, 20, 30, 40, 50, 60, 80	R 3 956.00	SN35K...
SM36A	3 + N	110 Vac	6	50 mA	117	5	10, 15, 20, 30, 40, 50, 60, 80	R 3 956.00	SN35L...
SM36A	3 + N	110 Vac	6	100 mA	117	5	10, 15, 20, 30, 40, 50, 60, 80	R 3 956.00	SN35M...
SM36A	3 + N	110 Vac	6	250 mA	117	5	10, 15, 20, 30, 40, 50, 60, 80	R 3 956.00	SN35N...
SM36A	3 + N	110 Vac	6	375 mA	117	5	10, 15, 20, 30, 40, 50, 60, 80	R 3 956.00	SN35P...
SM36A	3 + N	110 Vac	6	500 mA	117	5	10, 15, 20, 30, 40, 50, 60, 80	R 3 956.00	SN35Q...
SM36A	3 + N	110 Vac	6	1000 mA	117	5	10, 15, 20, 30, 40, 50, 60, 80	R 3 956.00	SN35R...
415 Vac Mining / Industrial Earth Leakage Protection Device, Three Phase with Overload Protection (Mini Rail)									L2
Type	Poles	Voltage	kA	mA	Width (mm)	Std. Pack	Rating (A)	Price Ea. excl. VAT	Order No.
SM36A	3 + N	415 Vac	6	50 mA	117	5	15, 20, 30, 40, 50, 60, 80	R 3 956.00	SM35L...
SM36A	3 + N	415 Vac	6	100 mA	117	5	15, 20, 30, 40, 50, 60, 80	R 3 956.00	SM35M...
SM36A	3 + N	415 Vac	6	250 mA	117	5	15, 20, 30, 40, 50, 60, 80	R 3 956.00	SM35N...
SM36A	3 + N	415 Vac	6	375 mA	117	5	15, 20, 30, 40, 50, 60, 80	R 3 956.00	SM35P...
SM36A	3 + N	415 Vac	6	500 mA	117	5	15, 20, 30, 40, 50, 60, 80	R 3 956.00	SM35Q...
SM36A	3 + N	415 Vac	6	1000 mA	117	5	15, 20, 30, 40, 50, 60, 80	R 3 956.00	SM35R...

Notes:

* Please contact CBi to determine the earth leakage configuration and availability.
Max cable size 50 mm² - SM.





MCB Accessories



Handle Lock



Safety Blank

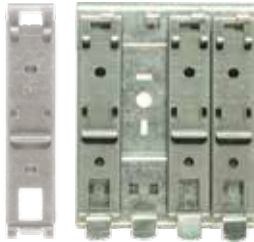

SAMR100



SAMR096

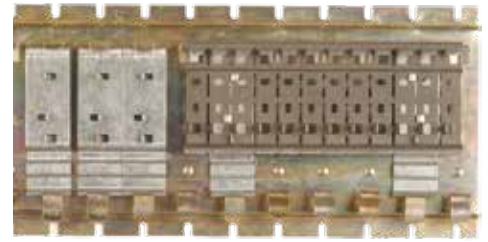

SAMR101



QANB18

**NEW
VERSION
AVAILABLE!**

Mini Rail				H2
Product	Description	Std. Pack	Price Ea. excl. VAT	Order No.
QA, QF (1 to 63 A)	Shroud - 2 x 13 mm / 1 x 26 mm, complete with surface mounting clip	10	R 83.00	3670093
QA, QF (1 to 63 A)	Shroud - 4 x 13 mm / 2 x 26 mm, complete with surface mounting clip	10	R 140.00	3670095
QA, QF (1 to 63 A)	Shroud - 6 x 13 mm / 3 x 26 mm, complete with surface mounting clip	10	R 173.00	3670097
QA, QF (1 to 63 A)	Shroud - 8 x 13 mm / 4 x 26 mm, complete with surface mounting clip	10	R 191.00	3670099
QF (70 to 125 A)	Shroud - 1 x 26 mm, complete with surface mounting clip	10	R 86.00	3670002
QF (70 to 125 A)	Shroud - 2 x 26 mm (open / knockout) complete with surface mounting clip	10	R 145.00	3670004
QF (70 to 125 A)	Shroud - 3 x 26 mm (open / knockout) complete with surface mounting clip	10	R 180.00	3670008
QF (70 to 125 A)	Shroud - 4 x 26 mm (open / knockout) complete with surface mounting clip	10	R 191.00	3670006
QA, QF	Shroud - sealing screws	100	R 7.00	3670012
QA, QF	Shroud - insert nuts	100	R 3.00	2096000
QA, QF	Mini rail - 13 mm module, 96 modules	10	R 77.00	SAMR096
Adaptor Plate	Heinemann clip tray to Samite	400	R 25.00	SAMR100
QA, QF	Insulating clip-on / terminal cover	1	R 3.00	2156995
QA	Safety blank - 13 mm module, clips into mini rail	100	R 18.00	SAEB000
SF, QF	Escutcheon blank - 26 mm module, clips into DB aperture	500	R 10.00	SFEB000
SF	Dummy - 26 mm single pole	50	R 38.00	SF1002601
QF High Rating	Surface mounting clips MK1 - price per 4 - way strip	40	R 12.00	SAAX000
SF	Surface mounting clips MK11 - price per pair (excl. sealing screws and insert nuts)	40	R 8.00	SFAX001
SAK	Contacting paralleling bars	10	R 20.00	3670011
Rail to Rail	Fuchs clip tray to mini rail adaptor plate	50	R 10.00	SAMR101
QANB18	Clip-in neutral bar (dual mount)	50	R 84.00	QANB18
QF	Escutcheon blank (6.5 mm module) 12 x 6.5 mm way strip	10	R 35.00	2356208
QA, QF	Shroud mounting kit (black)	10	R 42.00	3670145
QA, QF (1 to 63 A)	Handle lock	1	R 50.00	QFAP001
QFE (70 to 125 A)	Handle lock high rating	1	R 57.00	SXAP001
DIN Rail				H2
QA, QF (1 to 63 A)	Shroud - 2 x 13 mm / 1 x 18 mm - complete with surface mounting clip	10	R 83.00	3670094
QA, QF (1 to 63 A)	Shroud - 4 x 13 mm / 2 x 18 mm - complete with surface mounting clip	10	R 140.00	3670096
QA, QF (1 to 63 A)	Shroud - 6 x 13 mm / 4 x 18 mm - complete with surface mounting clip	10	R 173.00	3670098
QA, QF (1 to 63 A)	Shroud - 8 x 13 mm / 5 x 18 mm - complete with surface mounting clip	10	R 191.00	3670100

MCB Accessories



SABBM54

Mini and DIN Rail				H2
Product	Description	Std. Pack	Price Ea. excl. VAT	Order No.
QA, QF	Busbar - 13 mm module, single phase 54 modules	50	R 180.00	SABBM54
QA, QF	Top busbar - 13 mm module, single phase 26 modules	50	R 140.00	2121380
QFE	Busbar 26 mm - modules, single phase 36 modules	50	R 381.00	SABBM36
QA, QF	Insulating busbar cover - single phase	1	R 45.00	2176081
QA, QF	Busbar - 13 mm module, three phase insulated metre lengths (25 x 3 - phase)	1	R 1 454.00	3670010
QF	Busbar - 26 mm module, three phase insulated metre lengths (13 x 3 - phase)	1	R 1 446.00	3670009
QA, QF	Busbar link	50	R 18.00	SABL000
SF	Extended lug terminal	50	R 22.00	3190166
SA, SF, SH	Handle locking mechanism (Heilock)	10	R 46.00	SAAP001
QA / QF	Busbar 13 mm single phase + neutral	1	R 1 010.00	3190858
QA, QF DIN	Busbar - 18 mm modules, single phase 36 modules	50	R 178.00	2121363
QA, QF DIN	Top busbar - 18 mm module, single phase 19 modules	50	R 129.00	2121381
QA, QF DIN	Busbar - 18 mm module, three phase insulated metre lengths (16 x 3 phase)	1	R 1 454.00	3670121



Cascading Panel Labels				H2
Product	Description	Std. Pack	Price Ea. excl. VAT	Order No.
Small	Cascade panel label	1	R 13.00	2946A216
Large	Cascade panel label	1	R 54.00	2946A246

Auxiliary Products



QAT-TRDM



SAK

Electronic Time Switch (Dual Mount)				H2
Product	Description	Std. Pack	Price Ea. excl. VAT	Order No.
QAT-TRDM	Standard touch screen electronic time switch with 24 hour reserve, dual mount 39 mm width, escutcheons: mini rail 57 mm and DIN rail 45 mm	1	R 665.00	QAT-TRDM

Domestic Contactor (4 Pole Bridged Unit)				H2
Product	Description	Std. Pack	Price Ea. excl. VAT	Order No.
SAK	Contacteur 220 / 240 Vac - 4 Poles*	1	R 1 453.00	SAKR001
	AC3 (inductive load) - max 13 A (when bridged)			
	AC1 (resistive load) - max 40 A (when bridged)			

Note: * Bridge can easily be removed

Plastic Pole Mounting Box



SPB1



Plastic Pole Mounting Box



Operating Slide



Kit G - Non-ferrous



Kit F - Ferrous



Kit E - Non-ferrous



Kit D - Ferrous



Kit H - Non-Ferrous



Kit B - Ferrous

Plastic Pole Mounting Box				H2
Product	Description	Std. Pack	Price Ea. excl. VAT	Order No.
SPB1	Plastic pole mounting box complete with one operating slide (excludes mounting bracket MCBs, will accept 1, 2, 3 pole MCBs type QF, SF)	10	R 460.00	SPB1001
SPB1 Kit-B	Horizontal mounting bracket - ferrous	10	R 55.00	3674000
SPB1 Kit-D	Vertical mounting bracket - ferrous	10	R 68.00	3674001
SPB1 Kit-E	Vertical mounting bracket - non-ferrous	10	R 161.00	3670022
SPB1 Kit-F	Horizontal / vertical mounting bracket - ferrous	10	R 115.00	3674002
SPB1 Kit-G	Horizontal / vertical mounting bracket - non-ferrous	10	R 311.00	3670024
SPB1 Kit-H	Strapping bracket - non-ferrous	10	R 55.00	3670025
SPB1 Slide	Operating slide	10	R 39.00	3160058

Street Light Protection



On



Tripped



MCB not included - order separately
Wires not included

Street Light Protection				H2
Product	Description	Std. Pack	Price Ea. excl. VAT	Order No.
QAST001	Q-range, Polycarbonate actuator enclosure, with trip indication	1	R 50.00	QAST001



Distribution Boards



NRBCON002



NRBCON003

Ready Boards				L1
Order No.	Description	Std. Pack	Price Ea. excl. VAT	
NRBCON002	1 x QA17C 63 A; 2 x QA-1(13) 20 A; 3 x 16 A switched sockets; 1 x 6 A Euro socket; 1 x hinged dust cover	1	R 1 307.00	
NRBCON003	1 x QA17C 63 A; 2 x QA-1(13) 20 A; 3 x 16 A switched sockets; 1 x 6 A Euro socket; 1 x switched bulkhead; 1 x hinged dust cover	1	R 1 400.00	

Notes:

Other variations available on request, including a CFL (energy saver) version bulkhead.
Excludes bulb.



12-Way Flush Mounted



20-Way Flush Mounted

Flush Mount Distribution Boards				H2
Order No.	Description	Std. Pack	Price Ea. excl. VAT	
DBBOX12SP	12 - Way steel distribution board, complete with 1 plastic cover and 1 steel tray (mini rail)	1	R 304.00	
3190796	12 - Way steel distribution board, complete with 1 steel cover and 1 steel tray (mini rail)	1	R 301.00	
DBBOX20SP	20 - Way steel distribution, complete with 1 plastic cover and 1 steel tray (mini rail)	1	R 418.00	
3670107	20 - Way front cover (including hinged dust cover)	1	R 86.00	
3190795	20 - Way steel distribution board, complete with steel cover and 1 steel tray (mini rail)	1	R 469.00	

Surface Mount Distribution Boards				H2
Order No.	Description	Std. Pack	Price Ea. excl. VAT	
DBBOX12S	12 - Way steel distribution board, surface mount (CBi mini rail)	1	R 260.00	
DBBOX20S	20 - Way steel distribution, surface mount (CBi mini rail)	1	R 295.00	



40-Way



40-Way



60-Way

Architrave Distribution Boards				H2
Order No.	Description	Std. Pack	Price Ea. excl. VAT	
DBBOX40	40 - Way (2 x 20 - way and tray) ¹	1	R 1 853.00	
DBBOX40S	40 - Way architrave board surface mount	1	R 1 647.00	
DBBOX60	60 - Way (3 x 20 - way and tray) ¹	1	R 2 266.00	
DBBOX60S	60 - Way architrave board surface mount	1	R 2 016.00	

Note:

- Complete with reversible door, lockable metal latch, metal hinges, earth and neutral bars, mounting kit and manufacturing in 1.2 & 1.0 mm mild steel & powder coated white.

Distribution Boards



NEW!

DIN Solar DB

Pre-wired DIN Surface Mount Distribution Boards			NETT
Order No.	Description	Std. Pack	Price Ea. excl. VAT
SOLARDB3.6	Solar DB 3.6 kW, 12 - Way steel distribution board, complete with 1 plastic cover and 1 steel tray (DIN rail) with: 2 x QILD0001 indication lights 1 x QAD21360 60A main switch circuit breaker 1 x QAD21320 20 A inverter supply circuit breaker 1 x QAD21320 20 A inverter load circuit breaker 2 x QFLD0002 surge protection devices 1 x QAC40063 changeover switch 1 x QANB18 18-way neutral bar	1	R 1 893.00
SOLARDB5	Solar DB 5 kW, 12 - Way steel distribution board, complete with 1 plastic cover and 1 steel tray (DIN rail) with: 2 x QILD0001 indication lights 1 x QAD21360 60A main switch circuit breaker 1 x QAD21330 30 A inverter supply circuit breaker 1 x QAD21330 30 A inverter load circuit breaker 2 x QFLD0002 surge protection devices 1 x QAC40063 changeover switch 1 x QANB18 18-way neutral bar	1	R 1 893.00
SOLARDB8	Solar DB 8 kW, 12 - Way steel distribution board, complete with 1 plastic cover and 1 steel tray (DIN rail) with: 2 x QILD0001 indication lights 1 x QAD21360 60A main switch circuit breaker 1 x QAD21350 50 A inverter supply circuit breaker 1 x QAD21350 50 A inverter load circuit breaker 2 x QFLD0002 surge protection devices 1 x QAC40063 changeover switch 1 x QANB18 18-way neutral bar	1	R 1 893.00
Smart Pre-wired DIN Surface Mount Distribution Boards with ASPI			NETT
SOLARDB3.6S	Solar DB 3.6 kW, 12 - Way steel distribution board, complete with 1 plastic cover and 1 steel tray (DIN rail) with: 2 x QILD0001 indication lights 1 x QAD21360 60A main switch circuit breaker 1 x QAD21320 20 A inverter supply circuit breaker 1 x QAD21320 20 A inverter load circuit breaker 2 x QFLD0002 surge protection devices 1 x QAC40063 changeover switch 1 x QANB18 18-way neutral bar 1 x Astute Smart Power Indicator (ASPI)	1	R 2 271.00
SOLARDB5S	Solar DB 5 kW, 12 - Way steel distribution board, complete with 1 plastic cover and 1 steel tray (DIN rail) with: 2 x QILD0001 indication lights 1 x QAD21360 60A main switch circuit breaker 1 x QAD21330 30 A inverter supply circuit breaker 1 x QAD21330 30 A inverter load circuit breaker 2 x QFLD0002 surge protection devices 1 x QAC40063 changeover switch 1 x QANB18 18-way neutral bar 1 x Astute Smart Power Indicator (ASPI)	1	R 2 271.00
SOLARDB8S	Solar DB 8 kW, 12 - Way steel distribution board, complete with 1 plastic cover and 1 steel tray (DIN rail) with: 2 x QILD0001 indication lights 1 x QAD21360 60A main switch circuit breaker 1 x QAD21350 50 A inverter supply circuit breaker 1 x QAD21350 50 A inverter load circuit breaker 2 x QFLD0002 surge protection devices 1 x QAC40063 changeover switch 1 x QANB18 18-way neutral bar 1 x Astute Smart Power Indicator (ASPI)	1	R 2 271.00

Distribution Boards



**DC Protection Kit
Battery Protection Box**

DC Protection Kits - Battery Protection Boxes			NETT
Order No.	Description	Std. Pack	Price Ea. excl. VAT
BATBOX100	Battery Protection Box 100 A - metal enclosure with glands, DC circuit breakers and busbars with box terminal	1	R 919.00
BATBOX125	Battery Protection Box 125 A - metal enclosure with glands, DC circuit breakers and busbars with box terminal	1	R 919.00
BATBOX150	Battery Protection Box 150 A - metal enclosure with glands, DC circuit breakers and busbars with box terminal	1	R 919.00
BATBOX175	Battery Protection Box 175 A - metal enclosure with glands, DC circuit breakers and busbars with box terminal	1	R 919.00
BATBOX200	Battery Protection Box 200 A - metal enclosure with glands, DC circuit breakers and busbars with box terminal	1	R 919.00
BATBOX250	Battery Protection Box 250 A - metal enclosure with glands, DC circuit breakers and busbars with box terminal	1	R 919.00

Circuit Breaker Selection Guide

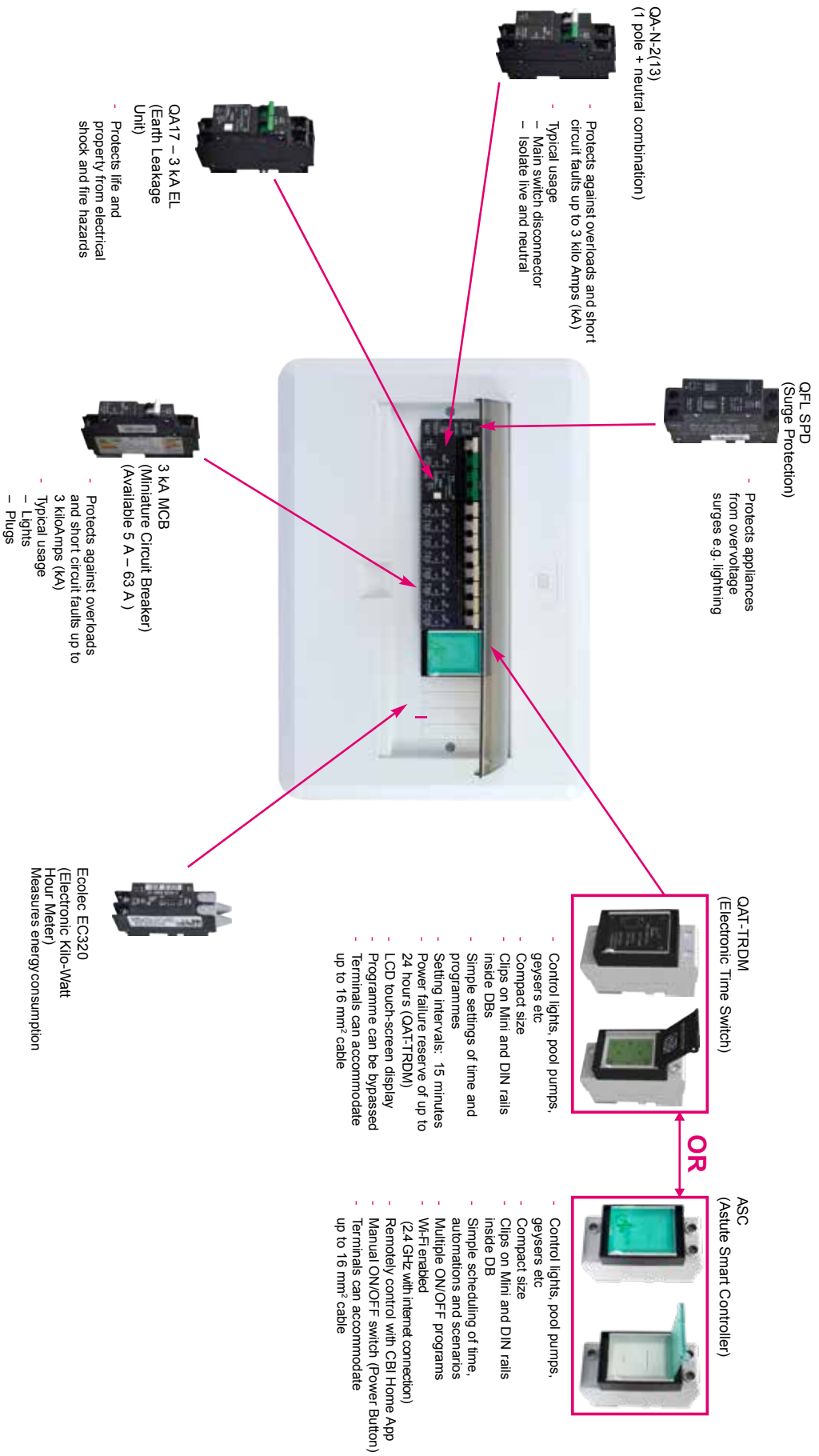

Rail Mount Meters (Class 1)



EC320CM



EC330CM



EC320CD



EC330CD

Ecolec Rail Mount Meters									E2
Type	Phase	Voltage	Frequency	Max Rating*	Escutcheon	No. Of Modules	Std. Pack	Price Ea. excl. VAT	Order No.
EC320CM	1 + N	230 V	50	80 A	57 mm	2	6	R 1 012.00	EC320CM
EC320CD	1 + N	230 V	50	80 A	45 mm	2	6	R 1 012.00	EC320CD
EC330CM	3 + N	415 V	50	80 A	57 mm	4	3	R 2 859.00	EC330CM
EC330CD	3 + N	415 V	50	80 A	45 mm	4	3	R 2 859.00	EC330CD

Notes:

Max cable size 35 mm²

* Anything above 80 A - CT needed

Rail Mount Meter

Rail mount meters are based on a meter module width of 13 mm with the single phase being 2 modules and the three phase 4 modules. The meter uses an integral current transformer as a measuring element and will count positive no matter from which direction the current is drawn. The display is a conventional cyclometer. The range included mini and DIN rail mounting, 230 V, 50 Hz.

Features

- SANS 1799 class 1 electricity meters
- Class 1: accuracy < 1%
- Single and three phase alternatives
- Fits all CBI mini and DIN rail distribution boards
- 7 Digit tamper-proof counter
- Anti-tamper terminal protection plugs
- Also available in 120 V / 60 Hz
- LED status and kWh consumption indicator
- Remote monitoring: LIN bus
- IP-45 rating
- 57 mm (dual mount) and 45 mm (DIN rail) escutcheon

LED Indications	
LED Indication	Reason / Description
Pulses RED	Normal consumption pulses (1000 pulses per kilo watt hour)
Pulses GREEN	Low load condition (consumption is less than 30 watts)
Solid GREEN	No load (meter is powered up)
Pulses ORANGE	Abnormal load (supply voltage is between 265 - 460 V or 60 - 90 Vac)
Solid ORANGE	Unsafe load condition (the current being drawn is greater than 125 A or the supply voltage is greater than 460 Vac)
Solid RED	Error condition (the meter's internal built in test has failed) / replace unit
No LED	No LED indication (insufficient supply voltage)



Wiring diagram

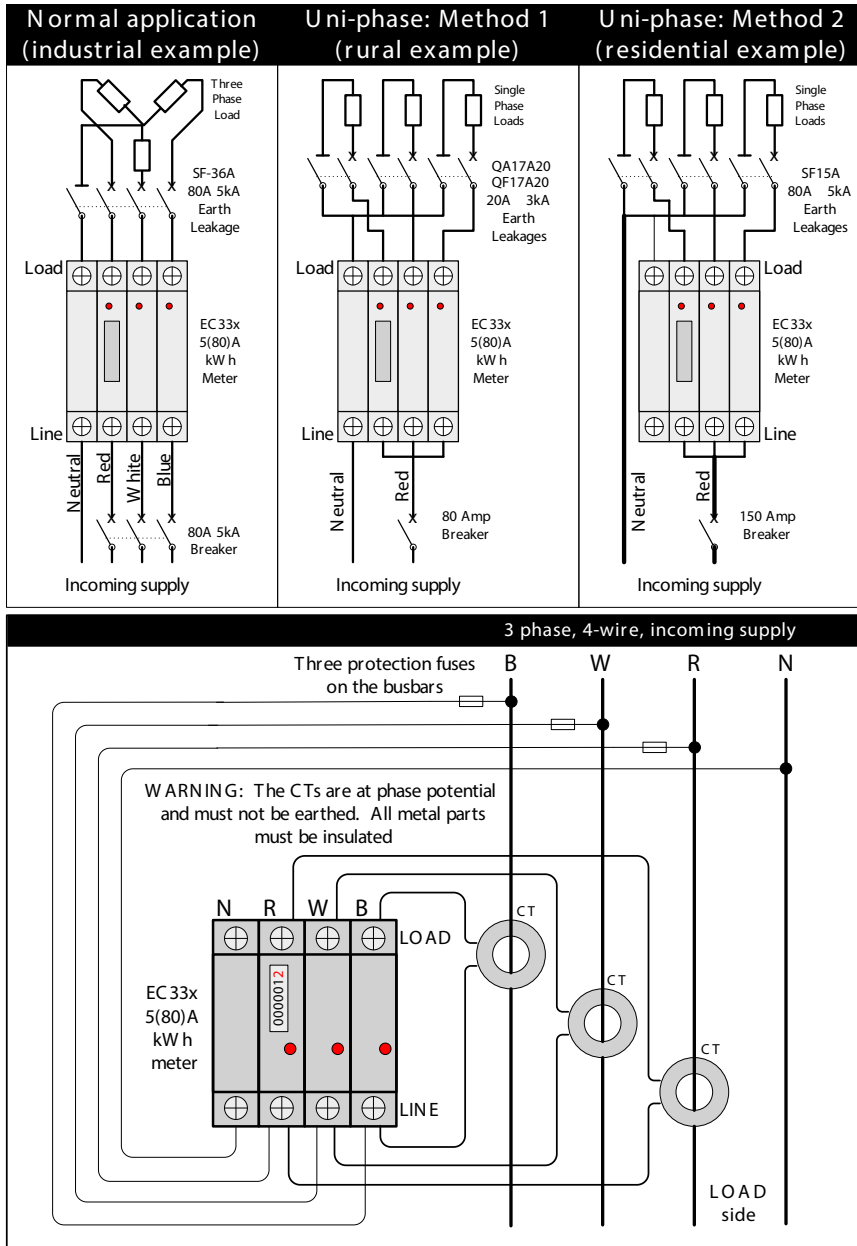

EC 300 series kWh consumption when using external CTs

There is a requirement to measure loads in excess of the meter's maximum current rating of 80 A. This can be done by using external CTs. Only class 1 type CTs are recommended for metering measurement purposes.

The actual kWh consumption per phase can be calculated as follows:

CT Ratio \times Δ Counter Value (multiply the CT ratio being used by the difference between the current and the previous meter reading)

E.g.: For a 200/5 CT ratio the factor is 40.

Therefore the consumption per phase = 40 x kWh consumed.

For CT Selection, please refer to the NRS057 specification parts 1, 2 and 4.

NOTE: Do not earth CTs fitted above!

Product Approvals

- SANS IEC 61036 test report MTR/BB0630-SR
- 5(80) A
- SANS 1799

Moulded Case Circuit Breaker Accessories

Moulded Case Circuit Breaker Interphase Barrier Selection Chart	
Interphase Barriers	CBI Range
FSAX004 (Set of 2)	JS25 , J25S J25SN
LBKIT (Set of 4)	L20B , L40B L20BN , L40BN
2176069 (Set of 2)	M25B , M35B , M50B M35BN
BAF-1SW (1 only)	G15D , G25D , G35D G35DN ELG25D3
BAF-2SV (1 only)	F15D , F25D , F35D F65DV F35DN ELF25D3 F10DDC
BAF-4SW (1 only)	K25D , K35D , K50D K35DE , K50DE , K65DE , K70DE K35DN , K50DN ELK35D3 K15DDC
BAF-8SW (1 only)	L35DE , L50DE , L70DE L35DN , L50DN
BAF-10SW (1 only)	N85DE1000X , N85DE1250X N85DN1000X , N85DN1250X
BAF-16SW (1 only)	N85DE1600X

Moulded Case Circuit Breaker Interphase Barrier Dimensions		
Interphase Barriers	Dimensions (mm)	
	A	B
FSAX004	88	73
LBKIT	93	80
2176069	155	100
BAF-1SW	50	59.5
BAF-2SV	100	59.5
BAF-4SW	110	98.5
BAF-8SW	110	98.5
BAF-10SW	110	132
BAF-16SW	185	132

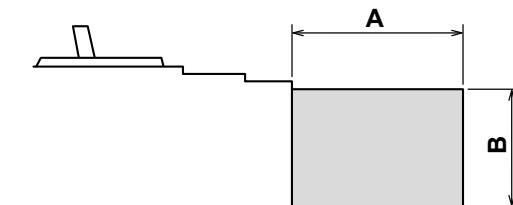
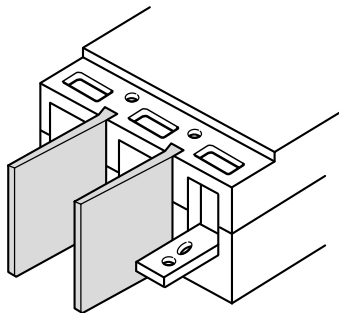



JS / JSN Range (Hydraulic-Magnetic)

	1P	3P
A	50 mm	105 mm
B	210 mm	210 mm
C	100 mm	100 mm

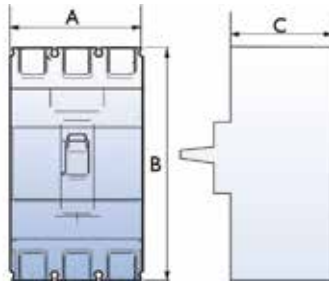

Distribution Circuit Breakers (Mixed Load) H2

Type	Barriers	Poles	Terminals	240 V	kA@ 415 V	525 V	Std. Pack	Rating (A)	Price Each excl. VAT	Order No.
JS25 ²		1	G1	25	-	-	1	80, 100	R 2 408.00	JSS0__
				25	-	-	1	125	R 2 503.00	JSS0125
			G4B	25	-	-	1	150	R 2 718.00	JSS0150
				200	-	-	1	200	R 2 807.00	JSS0200
				250	-	-	1	250	R 3 114.00	JSS0250
J25S	4	3	G1	-	25	15	1	50, 60	R 4 794.00	JSO0__
				-	25	15	1	80, 100	R 4 854.00	JSO0__
				-	25	15	1	125	R 5 093.00	JSO0125
			G4B	-	25	15	1	150	R 5 400.00	JSO0150
				-	25	15	1	160, 175, 200	R 6 433.00	JSO0__
				-	25	15	1	225	R 6 493.00	JSO0225
				-	25	15	1	250	R 7 629.00	JSO0250

Switch Disconnectors¹ Red Handle H2

Type	Barriers	Poles	Terminals	240 V	kA@ 415 V	525 V	Std. Pack	Rating (A)	Price Each excl. VAT	Order No.
J25SN	4	3	G1	-	25++	15++	1	100	R 3 128.00	JSN0100
				-	25++	15++	1	150	R 4 075.00	JSN0150
			G4B	-	25++	15++	1	200	R 5 300.00	JSN0200
				-	25++	15++	1	250	R 6 200.00	JSN0250

JS Accessories H2

Description LH = Left Hand Side RH = Right Hand Side	Factory Fitted	Std. Pack	Voltage - AC	Voltage - DC	Price Each excl. VAT	Order No.	
Shunt trip	RH	Yes	1		24	R 1 299.00	FSAA001
	RH		1	110 - 250		R 1 299.00	FSAA002
	RH		1	380 - 600		R 1 299.00	FSAA003
Undervoltage release	RH	Yes	1	220 - 250		R 1 644.00	FSAC220
	RH		1	380 - 440		R 1 644.00	FSAC380
Auxiliary Switch			1			R 631.00	FSAH002
Trip alarm switch			1			R 756.00	FSAF001
2 x Auxiliary switch			1			R 1 247.00	FSAR001
1 x Auxiliary + 1 x trip alarm switch			1			R 1 971.00	FSAV001
Handle lock plastic			1			R 123.00	FSAP001
(G4B) Stub bar			Set			R 293.00	FSAX001
(G5) Tandem box terminal (250 A Max) (3 per set - line or load side)			Set			R 965.00	FSAX002
Interphase barriers (Qty 2 only)			Set			R 113.00	FSAX004
Terminal covers (each) (line or load)			1			R 405.00	FSAX005

Notes:

- Withstand current must be backed up by suitable Short Circuit Protection Device (SCPD). ++To IEC 60947-3.
 - Accessories cannot be fitted to a single pole JS breaker
- Please contact CBI for Amp Ratings not listed

LB / LBN Range (Hydraulic-Magnetic)



L20B



L40B

A	150 mm
B	300 mm
C	105 mm

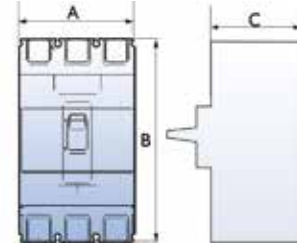

Distribution Circuit Breakers (Mixed Load) H2									
Type	Barriers	Poles	Terminals	kA@ 415 V Icu Ics		Std. Pack	Rating (A)	Price Each excl. VAT	Order No.
L20B	4	3	G1	20	20	1	100, 125, 150	R 8 005.00	L20B___
							175, 200, 225	R 9 820.00	L20B___
							250	R 10 382.00	L20B250
							300	R 12 339.00	L20B300
							350, 400	R 14 615.00	L20B___
							450, 500	R 21 067.00	L20B___
							600	R 22 066.00	L20B600
L40B	4	3	G1	40	20	1	100, 125, 150	R 8 854.00	L40B___
							175, 200, 225	R 10 804.00	L40B___
							250	R 11 471.00	L40B250
							300	R 13 574.00	L40B300
							350, 400	R 16 072.00	L40B___
							450, 500	R 23 174.00	L40B___
							600	R 24 272.00	L40B600

Switch Disconnectors ¹ H2								
Type	Barriers	Poles	Terminals	Withstand kA@ 415 V	Std. Pack	Rating (A)	Price Each excl. VAT	Order No.
L20BN	4	3	G1	20++	1	300	R 10 679.00	L20BN0300
						400	R 11 316.00	L20BN0400
						500	R 15 285.00	L20BN0500
						600	R 15 441.00	L20BN0600
L40BN	4	3	G1	40++	1	300	R 11 746.00	L40BN0300
						400	R 12 448.00	L40BN0400
						500	R 16 812.00	L40BN0500
						600	R 16 980.00	L40BN0600

LB Accessories H2					
Description	Factory Fitted	Std Pack	Voltage - AC	Price Each excl. VAT	Order No.
Shunt trip	Yes	1	110	R 2 802.00	LBSHT110
Shunt trip			220 - 240	R 2 802.00	LBSHT220
Shunt trip*			380 - 415	R 2 802.00	LBSHT380
Auxiliary switch	Yes	1		R 1 247.00	LBAUX
Trip alarm switch	Yes	1		R 1 148.00	LBALARM
(G4B) Stub busbar 600 A Max		Set of 3		R 1 540.00	4120166
Interphase barriers (Qty 4 only)		Set		R 142.00	LBKIT

Notes:

1. Withstand current must be backed up by suitable Short Circuit Protection Device. ++SABS / IEC 60947-3

* Contact CBi for availability

All Accessories are factory-fitted only

Please fill in required AMP rating on dotted line of order number column

MCCB and Accessories

MB / MBN Range (Hydraulic-Magnetic)

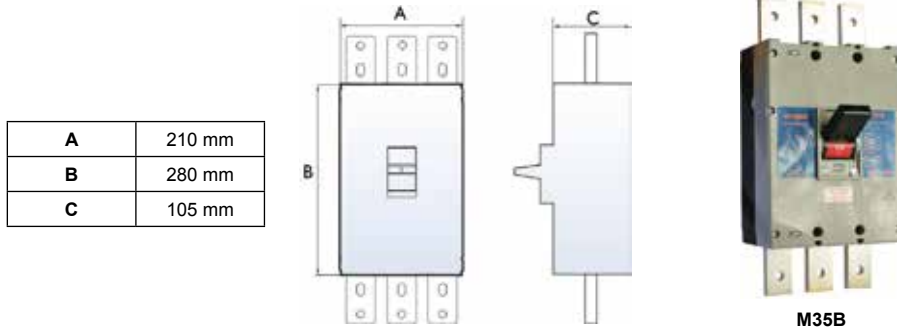

Distribution Circuit Breakers (Mixed Load)

H2

Type	Barriers	Poles	Terminals	kA@ 415 V	Std. Pack	Rating (A)	Price Each excl. VAT	Order No.
M25B	4	3	G4B	25++	1	700, 830	R 37 198.00	MB25__
M35B	4	3	G4B	35	1	700, 830	R 38 178.00	MB35__
M50B	4	3	G4B	50++	1	700, 830	R 38 960.00	MB50__

Triple Pole Switch Disconnect¹

H2

M35BN	4	3	G4B	35++	1	830	R 32 304.00	MBN0830
-------	---	---	-----	------	---	-----	-------------	---------

MB Accessories

H2

Description	Std. Pack	Voltage - AC	Price Each excl. VAT	Order No.
Shunt trip with cut-out, both leads out	1	220	R 4 273.00	MBAA220
	1	380	R 4 273.00	MBAA380
Interphase barriers (Qty 2 only)	Set		R 180.00	2176069

Notes:

- Withstand current must be backed up by suitable short circuit protection device (SCPD)
All MB type circuit breakers and switch disconnectors come complete with 4 phase barriers and mounting hardware
All accessories are factory-fitted only
Please fill in required amp rating on dotted line of order number column

GD / GDN / FD / FDN Range (Thermal-Magnetic)

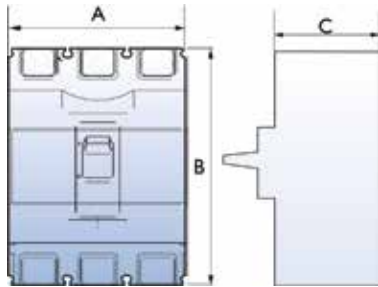

	G15D / G25D	F15D / F25D	G35D	F35D	F65DV
	16 - 125 A	150 - 250 A	16 - 100 A	125 - 250 A	16 - 250 A
A	90 mm	105 mm	90 mm	105 mm	105 mm
B	130 mm	165 mm	130 mm	165 mm	165 mm
C	68 mm	68 mm	68 mm	68 mm	68 mm



G15D

F35D

Triple Pole Circuit Breakers (Mixed Load)								H2
Type	Poles	Terminals	kA@		No. of Interphase Barriers	Rating (A)	Price Each excl. VAT	Order No.
			415 V	525 V				
G15D	3	G1	15	15	2	16, 20, 32, 40, 50, 63	R 3 361.00	G15D__
		G1	15	15		80, 100	R 3 840.00	G15D__
		G1	15	15		125	R 4 128.00	G15D125
F15D	3	G1	15	15	4	150, 160	R 4 515.00	F15D__
		G1	15	15		175, 200, 225	R 7 530.00	F15D__
		G4B	15	15		250	R 8 232.00	F15D250
G25D	3	G1	25	18	2	16, 20, 32, 40, 50, 63	R 4 070.00	G25D__
		G1	25	18		80, 100	R 4 195.00	G25D__
		G1	25	18		125	R 4 285.00	G25D__
F25D	3	G1	25	22	4	150, 160	R 4 964.00	F25D__
		G1	25	22		175, 200, 225	R 8 130.00	F25D__
		G4B	25	22		250	R 8 770.00	F25D250
G35D	3	G1	35	22	2	16, 20, 32, 40, 50, 63	R 4 675.00	G35D__
		G1	35	22		80, 100	R 5 530.00	G35D__
F35D	3	G1	35	22	4	125	R 5 704.00	F35D125
		G1	35	30		150, 160	R 5 854.00	F35D__
		G1	35	30		175, 200, 225	R 10 610.00	F35D__
		G4B	35	30		250	R 11 416.00	F35D250
F65DV ¹	3	G1	65	35	4	20-25, 32-40, 45-63	R 6 986.00	F65DV__
		G1	65	35		70-100	R 7 429.00	F65DV70-100
		G1	65	35		90-125	R 7 687.00	F65DV90-125
		G1	65	35		125-160	R 8 514.00	F65DV125-160
		G4B	65	35		175-250	R 11 463.00	F65DV175-250

Switch Disconnectors ²								H2
Type	Poles	Terminals	Withstand kA@		No. of Interphase Barriers	Rating (A)	Price Each excl. VAT	Order No.
			415 V	525 V				
G35DN	3	G1	30++	18++	2	125	R 2 894.00	G35DN125
F35DN	3	G1	30++	22++	2	160	R 4 301.00	F35DN160
F35DN	3	G4B	30++	22++	2	250	R 5 752.00	F35DN250

Notes:

1. Thermal adjustable
2. Withstand current must be backed up by suitable Short Circuit Protection Device (SCPD)

FD 250 A breakers come complete with G4B stub busbars (set of 6)

++ To IEC 60947-3

Insulation Voltage / V _{ins}	690 V
Impulse Withstand / V _{imp}	6 / 8 kV
Poles	3P



F65DV



GD & FD Compatible Accessories

G15D, G25D, G35D, F15D, F25D, F35D & F65DV C

Description LH = Left Hand Side, RH = Right Hand Side		Std. Pack	Voltage - AC	Price Each excl. VAT	Order No.
Shunt trip	LH/RH	1	24 - 48	R 624.00	SHTA048-05SVLS/RS
	LH/RH	1	100 - 240	R 624.00	SHTA240-05SVLS/RS
	LH/RH	1	380 - 550	R 624.00	SHTA550-05SVLS/RS
Undervoltage release	LH/RH	1	24	R 1 311.00	UVTNA024-05SVLS/RS
	LH/RH	1	48	R 1 311.00	UVTNA048-05SVLS/RS
	LH/RH	1	100-110 / 120-130	R 1 311.00	UVTNA130-05SVLS/RS
	LH/RH	1	200-220 / 230-250	R 1 311.00	UVTNA250-05SVLS/RS
	LH/RH	1	380-415 / 440-480	R 1 311.00	UVTNA480-05SVLS/RS
	LH/RH	1	550-550 / 600	R 1 311.00	UVTNA600-05SVLS/RS
Auxiliary switch	LH/RH	1		R 432.00	AX-05SVLS/RS
Double auxiliary switch	LH	1		R 1 145.00	AX2-05SVLS
Alarm auxiliary switch	LH	1		R 889.00	ALAX-05SVLS

GD Dedicated Accessories

G15D, G25D & G35D C

Description LH = Left Hand Side, RH = Right Hand Side		Std. Pack	Voltage - AC	Price Each excl. VAT	Order No.
Line and load shrouds		1		R 365.00	TCL-1SV3W
Motor operator 220 V 50 Hz		1	100-240 (AC / DC)	R 17 456.00	MDS240-1SV
(G4B) Stub busbar (Qty 3 only)		Set		R 304.00	FB-1SV
Handle lockout		1		R 445.00	HLS-05SV
Interphase barriers (Qty 1 only)		1		R 141.00	BAF-1SW

FD Dedicated Accessories

F15D, F25D, F35D & F65DV C

Description LH = Left Hand Side, RH = Right Hand Side		Std. Pack	Voltage - AC	Price Each excl. VAT	Order No.
Line and load shrouds		1		R 978.00	TCL-2SV3W
Motor operator 220 V 50 Hz		1	100-240 (AC / DC)	R 17 456.00	MDS240-2SV
Handle lockout		1		R 445.00	HLS-2SV
Interphase barriers (Qty 1 only)		1		R 144.00	BAF-2SV

GD & FD Adaptor Plate H2

Adaptor plate GD & FD - old Fuchs range to new range (depth C adjustment)		1		R 143.00	FD-ADAPTOR ¹
---	--	---	--	----------	-------------------------

Stub Bar F15D, F25D, F35D & F65DV H2

(G4B) Stub busbar (Qty 3 only)		Set		R 293.00	FSAX001
--------------------------------	--	-----	--	----------	---------

Extension Handle G15D, G25D & G35D C2

Extension handle (Std. shaft - 300 mm)		1		R 2 195.00	12MEC.1145
--	--	---	--	------------	------------

Extension Handle F15D, F25D, F35D & F65DV C2

Extension handle (Std. shaft - 300 mm)		1		R 2 195.00	12MEC.1045
--	--	---	--	------------	------------

Note: MCCB with indicated profile must be fitted with the "compatible" accessory range.

1. FD-ADAPTOR - adjustment from old 86 mm Fuchs breaker depth to new FD and GD Range.

F65DV Accessories

F65DV Accessories C				
Description LH = Left Hand Side, RH = Right Hand Side	Std. Pack	Voltage - AC	Price Each excl. VAT	Order No. F65DV
Motor operator 220 V 50 Hz	1	100-240 (AC / DC)	R 17 456.00	MDS240-2SV
Handle lockout	1		R 445.00	HLS-2SV
Interphase barriers (Qty 1 only)	1		R 144.00	BAF-2SV

Extension Handle C2				
Extension handle (Std. shaft - 300 mm)	1		R 2 195.00	12MEC.1045

Thermal and Magnetic Adjustable Chart - FDV	
Type	Thermal ²
F65DV 20-25 A	20 - 25
F65DV 32-40 A	32 - 40
F65DV 45-63 A	45 - 63
F65DV 70-100 A	70 - 100
F65DV 90-125 A	90 - 125
F65DV 125-160 A	125 - 160
F65DV 175-250 A	175 - 250

Notes:

2. Thermals are adjustable in fixed steps as per adjustability chart



KD / KDN Range (Thermal-Magnetic), KDE Range (Electronic)

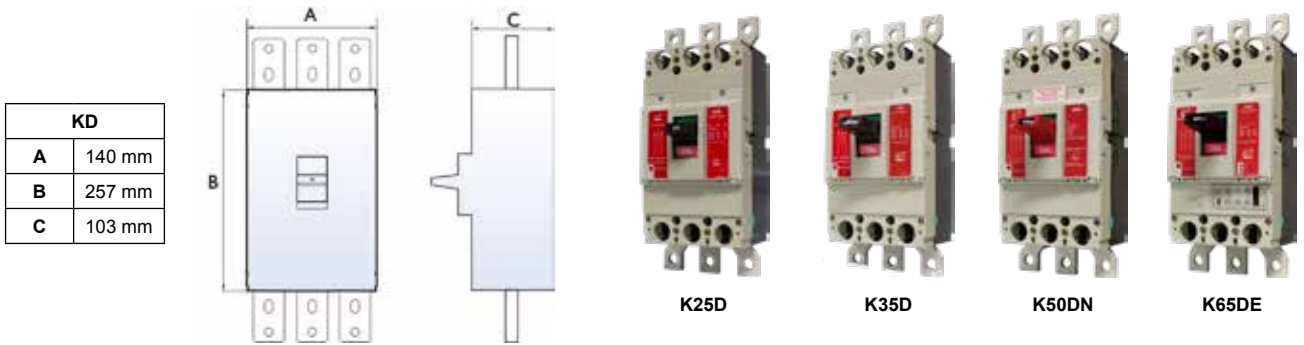

KD Circuit Breakers (Mixed Load) H2

Type	Poles	Terminals	Withstand kA@			No. of Interphase Barriers	Rating (A)	Price Each excl. VAT	Order No.
			415 V	500 V	525 V				
K25D	3	G4B	25	22	-	4	250	R 10 753.00	K25D250
	3	G4B	25	22	-	4	300, 350, 400	R 12 883.00	K25D__
K35D	3	G4B	35	30	30	4	250	R 12 596.00	K35D250
	3	G4B	35	30	30	4	300, 350, 400	R 17 013.00	K35D__
	3	G4B	36	22	-	4	500, 630	R 22 135.00	K35D__X
K50D	3	G4B	50	40	35	4	500, 630	R 24 580.00	K50D__X

KDE Electronic Circuit Breakers (Adjustable) H2

Type	Poles	Terminals	Withstand kA@			No. of Interphase Barriers	Rating (A)	Price Each excl. VAT	Order No.
			415 V	500 V	525 V				
K35DE	3	G4B	35	30	30	4	200-400	R 20 624.00	K35DE400
K50DE	3	G4B	50	40	35	4	300-630	R 32 274.00	K50DE630X
K65DE	3	G4B	65	50	50	4	200-400	R 21 894.00	K65DE400
K70DE	3	G4B	70	50	-	4	300-630	R 36 160.00	K70DE630X

Switch Disconnectors¹ H2

Type	Poles	Terminals	Withstand kA@			No. of Interphase Barriers	Rating (A)	Price Each excl. VAT	Order No.
			415 V	500 V	525 V				
K35DN	3	G4B	35++	22++	-	4	300	R 11 727.00	K35DN300
	3	G4B	35++	22++	-	4	400	R 12 278.00	K35DN400
	3	G4B	36++	22++	-	4	630	R 15 657.00	K35DN630X
K50DN	3	G4B	50++	40++	35++	4	630	R 21 217.00	K50DN630X

Notes:

1. Backed up by suitable Short Circuit Protection Device (SCPD)
++ To IEC 60947-2 / 3



KD Accessories

KD Accessories					C
Description LH = Left Hand Side, RH = Right Hand Side	Std. Pack	Voltage - AC	Price Each excl. VAT	Order No.	
Shunt trip	RH	1	24-48 (AC / DC)	R 2 126.00	SHT48-4SWRS
	LH/RH	1	100-450 Vac / 100-200 Vdc	R 1 264.00	SHT-4SWLS/RS
	RH	1	380 - 550	R 1 264.00	SHTA550-4SWRS
Undervoltage release	LH/RH	1	110-120	R 2 275.00	UVTA120-4SWS
	LH/RH	1	220-240	R 2 275.00	UVTA240-4SWS
	LH/RH	1	380-415	R 2 275.00	UVTA415-4SWS
	LH/RH	1	500-550	R 2 275.00	UVTA550-4SWS
Auxiliary switch	LH/RH	1		R 822.00	AX-4SWLS/RS
Double auxiliary	LH	1		R 1 081.00	AX2-4SWLS
Alarm auxiliary switch	LH	1		R 1 074.00	ALAX-4SWLS
Motor operator		1	200-220	R 11 058.00	MDS-4SWA220
Interphase barriers (Qty 1 only)		1		R 163.00	BAF-4SW
Handle lockout		1		R 558.00	HLS-4SW
Cylindrical lock* (same key)		1		R 994.00	4470113
Cylindrical lock* (different key)		1		R 994.00	4470112
Line and load shroud (terminal cover)		2		R 1 110.00	TCL-4SW3

Extension Handle					C2
Extension handle (Std. shaft - 300 mm)		1		R 2 349.00	12MEC.0645



LDE / LDN Range

LDE	
A	210 mm
B	275 mm
C	103 mm

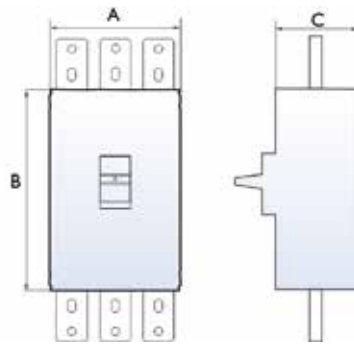

Triple Pole Circuit Breakers (Mixed Load) Adjustable in Fixed Steps H2

Type	Poles	Terminals	kA@			No. of Interphase Barriers	Rating (A)	Price Each excl. VAT	Order No.
			415 V	500 V	525 V				
L35DE	3	G4B	36++	22++	-	2	400-800	R 33 799.00	L35DE800X
L50DE	3	G4B	50++	40++	25++	2	400-800	R 39 467.00	L50DE800X
L70DE	3	G4B	70++	50++	15++	2	400-800	R 43 412.00	L70DE800X

Triple Pole Switch Disconnectors¹ H2

Type	Poles	Terminals	Withstand kA@			No. of Interphase Barriers	Rating (A)	Price Each excl. VAT	Order No.
			415 V	500 V	525 V				
L35DN	3	G4B	35++	-	-	2	800	R 21 346.00	L35DN800X
L50DN	3	G4B	50++	40++	25++	2	800	R 25 678.00	L50DN800X

Notes:

1. Backed up by suitable Short Circuit Protection Device (SCPD)
++To IEC 60947 - 2 / 3

LDE and LDN Accessories C

Description LH = Left Hand Side, RH = Right Hand Side		Std. Pack	Voltage - AC	Price Each excl. VAT	Order No.
Shunt trip	RH	1	24-48 (AC / DC)	R 2 126.00	SHT48-4SWRS
	LS/RS	1	100 - 450	R 1 264.00	SHT-4SWLS/RS
	RH	1	380 - 550	R 1 264.00	SHTA550-4SWRS
Undervoltage release	LS/RS	1	110-120	R 2 275.00	UVTA120-4SWS
	LS/RS	1	220-240	R 2 275.00	UVTA240-4SWS
	LS/RS	1	380-415	R 2 275.00	UVTA415-4SWS
	LS/RS	1	500-550	R 2 275.00	UVTA550-4SWS
Auxiliary switch (1N/0 + 1N/C)	LS/RS	1		R 822.00	AX-4SWLS/RS
Double auxiliary (2N0 2NC)	LH	1		R 1 081.00	AX2-4SWLS
Alarm auxiliary switch	LH	1		R 1 074.00	ALAX-4SWLS
Spring charge unit MDS type 220 Vac	LH	1	200-220	R 11 058.00	MDS-8SWA220
Key interlock - Cylindrical type		1		R 994.00	4470113
Interphase barriers (Qty 1 only)		1		R 183.00	BAF-8SW
Terminal cover		1		R 1 387.00	TCL-8SW3

Extension Handle C2

Extension handle (Std. shaft - 300 mm)	1		R 3 053.00	12MEC.0845
--	---	--	------------	------------

NDE / NDN Range



A	210 mm
B	406 mm
C	140 mm

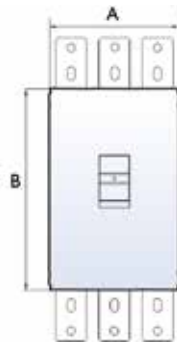

N85DE



N85DN

Triple Pole Circuit Breakers (Mixed Load) Electronic Adjustable								H2
Type	Poles	Terminals	kA@		No. of Interphase Barriers	Rating (A)	Price Each excl. VAT	Order No.
			415 V	500 V				
N85DE	3	G4B	85++	65++	2	500-1000	R 44 454.00	N85DE1000X
	3				2	600-1250	R 53 097.00	N85DE1250X
	3				2	800-1600	R 76 740.00	N85DE1600X

Triple Pole Switch Disconnectors ¹								H2
Type	Poles	Terminals	kA@		No. of Interphase Barriers	Rating (A)	Price Each excl. VAT	Order No.
			415 V	500 V				
N85DN	3	G4B	85++	65++	2	1000	R 37 731.00	N85DN1000X
	3				2	1250	R 48 095.00	N85DN1250X

NDE and NDN Accessories							C
Description LH = Left Hand Side, RH = Right Hand Side		Factory Fitted	Std. Pack	Voltage - AC	Price Each excl. VAT	Order No.	
Shunt trip	RH	Yes	1	100 - 120	R 3 198.00	SHTA120-10SWRS	
	RH	Yes	1	200 - 240	R 3 198.00	SHTA240-10SWRS	
	RH	Yes	1	380 - 450	R 3 198.00	SHTA450-10SWRS	
	RH	Yes	1	500 - 550	R 3 198.00	SHTA550-10SWRS	
Undervoltage release	RH	Yes	1	100 - 120	R 3 353.00	UVTNA130-10SWRS	
	RH	Yes	1	200 - 240	R 3 353.00	UVTNA240-10SWRS	
	RH	Yes	1	380 - 450	R 3 353.00	UVTNA450-10SWRS	
	RH	Yes	1	500 - 550	R 3 353.00	UVTNA550-10SWRS	
Auxiliary switch (1N/0 + 1N/C)	LH/RH	Yes	1	-	R 1 142.00	AX-10SWLS/RS	
Alarm + auxiliary switch combined	LH	Yes	1	-	R 1 889.00	ALAX-10SWLS	
Double auxiliary (2NO 2NC)	LH	Yes	1	-	R 4 349.00	AX2-10SWLS	
Spring charge unit MDS type		Yes	1	220 - 220	R 57 348.00	MD-10SWA220	
Key interlock - cylindrical type		Yes	1	-	R 994.00	4470113	
Interphase barriers (Qty 1 only) N85DE1000X / N85DE1250X N85DN1000X / N85DN1250X			1	-	R 183.00	BAF-10SW	
Interphase barriers (Qty 1 only) N85DE1600X / N85DN1600X			1	-	R 219.00	BAF-16SW	

Extension Handle					C2
Extension handle mechanism (Std. shaft - 300 mm)	1			R 3 923.00	12MEC.0945

Notes:

- Backed up by Suitable Short Circuit Protection Device (SCPD)
++ To IEC 60947-2 / 3
Electronic Adjustable MCCBs are ideal for Tripping Co-ordination / Discrimination

ELGD / ELFD / ELKD Range (Thermal-Magnetic, Electronic)

	EL3G	EL3F	ELK
	3P	3P	3P
A	90 mm	105 mm	140 mm
B	130 mm	165 mm	257 mm
C	68 mm	68 mm	103 mm

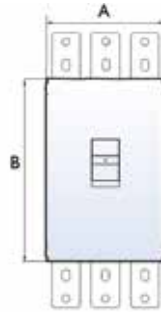

ELK35D



Integral Earth Leakage Circuit Breakers (Mixed Load) not for 4-Wire systems

H2

Type	Poles		Terminals	kA@			Sensitivity mA	No. of Interphase Barriers	Rating (A)	Price Each excl. VAT	Order No.
	CB	E/L		380 V	400 V	525 V					
EL3G25D	3	3	G1	25	25	15	30,175, 250 ¹	2	16, 20, 32, 40, 50, 63	R 9 066.00	ELG25D3...
								2	80, 100, 125	R 9 585.00	
EL3F25D	3	3	G1	25	25	15	30, 250, 375 ¹	4	150, 175	R 11 931.00	ELF25D3...
								4	200, 225, 250	R 13 998.00	
EL3K35D	3	3	G4B	35	35	25	100, 300, 500 ²	4	250	R 18 649.00	ELK35D3...
								4	300	R 25 608.00	
								4	400	R 27 523.00	
								4	630	R 33 840.00	

Notes:

CB = Circuit Breaker Poles

E/L = Earth Leakage Poles

- Sensitivity: Adjustable (instantaneous tripping time). Other units available on request (contact CBI for availability)
- Sensitivity: Adjustable mA and time delay setting (0.45, 1.0 2.0 s)
- Sensitivity: 30 mA fixed rating (instantaneous tripping time)

• For "EL3G/EL3F/EL3K" Accessories, refer to GD, FD and KD accessories (only the left hand cavity is available for fitting of accessories)

* Contact CBI for availability (Non Stock items)

Please fill in required Amp rating on dotted line of order number column

Technical

NB: Phase EL'S without Neutral are not suitable for all 4 wire systems

DC MCCBs for Traction Control

Triple Pole Circuit Breakers for DC Traction

H2

Type	Poles	Terminals	kA @ 440 Vdc	No. of Interphase Barriers	Rating (A)	Price Each excl. VAT	Order No.
F10DDC	3	G2	10	4	150	R 4 670.00	F10DDC150
	3	G2	10	4	250	R 7 831.00	F10DDC250

Triple Pole Circuit Breakers for DC Traction

H2

Type	Poles	Terminals	kA @ 440 Vdc	No. of Interphase Barriers	Rating (A)	Price Each excl. VAT	Order No.
K15DDC	3	G4B	15	4	300	R 14 410.00	K15DDC300
	3	G4B	15	4	400	R 14 806.00	K15DDC400

Earth Leakage Relays EL305 / EL306



A	105 mm
B	125 mm
C	57 mm
Ø	50 mm

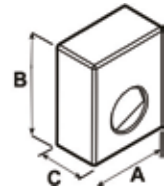

Earth Leakages Relays EL305 include Mounting Plate H2

Type	Sensitivity code	Standard Voltage	Sensitivity mA	Std. Pack	Remote Core if Required (mm) Sold Separately	Price Each excl. VAT	Order No.
EL305 Complete with clip tray	Y	110, 220, 380, 525	30	1	Not available	R 4 424.00	QC5Y00...
	Z	110, 220, 380, 525	50	1	Not available	R 4 424.00	QC5Z00...
	AA	110, 220, 380, 525	125	1	Not available	R 3 867.00	QC5AA0...
	A	110, 220, 380, 525	250	1	70, 105	R 3 239.00	QC5A00...
	B	110, 220, 380, 525	500	1	70, 105, 152, 190	R 3 239.00	QC5B00...
	J	110, 220, 380, 525	1000	1	70, 105, 152, 190	R 3 927.00	QC5J00...
	L	110, 220, 380, 525	2000	1	70, 105, 152, 190	R 3 927.00	QC5L00...
	K	110, 220, 380, 525	5000	1	70, 105, 152, 190	R 3 927.00	QC5K00...

Inverse Definite Minimum Time (IDMT) Earth Leakage Relay EL306 H2

Type	Sensitivity code	Standard Voltage	Sensitivity mA	Std. Pack	Remote Core if Required (mm) Sold Separately	Price Each excl. VAT	Order No.
EL306 Complete with clip tray	F	110 - 525	375	1	70, 105	R 3 888.00	QC06F00...
	C	110 - 525	500	1	70, 105	R 3 888.00	QC06C00...
	D	110 - 525	1000	1	70, 105, 152	R 4 112.00	QC06D00...
	E	110 - 525	2000	1	70, 105, 152, 190	R 4 543.00	QC06E00...
	H	110 - 525	5000	1	70, 105, 152, 190	R 3 834.00	QC06H00...

Notes:

Remote cores available, made to order only, contact CBi
Remote core and earth leakage must be a matched pair (factory calibrated)

If the sum of the conductor's outside diameter is greater than 50 mm, a remote must be purchased with the EL305 / 6

Hospital Earth Leakage Monitor (Early Bird)



EB225H

Hospital Earth Leakage Monitor H2

Type	Poles	Voltage	Std. Pack	Price each	Order No.
EB225H (Early bird)	1+N	230 V	1	R 13 295.00	EB99900



ELP15

Portable Earth Leakage Units

Portable Earth Leakage Units AC 15 A 50 Hz, 6 kA @ 230 V, 30 mA H2

Type		Std. Pack	Price each	Order No.
ELP15	Fitted with 3 standard 15 A round pin socket outlets & 15 A overload protection	1	R 4 514.00	LP36K15

V-Series - Circuit Breakers / Switch Disconnectors



NF125-SVA



Circuit Breakers V Series SVA / SGV

Type	Poles	Terminals	kA@			No. of Interphase Barriers	Rating (A)	Price Each excl. VAT	Order No.
			415 V	500 V	525 V				
NF125-SVA	3	G1	30	18	18	2	16, 20, 32, 40, 50, 63	R 4 248.00	NF125SVA...
		G1	30	18	18		80, 100, 125	R 4 909.00	NF125SVA...
NF250-SVA	3	G1	30	22	22	4	125	R 6 275.00	NF250SVA125
		G1	30	22	22		150, 160	R 7 190.00	NF250SVA...
		G1	30	22	22	4	175, 200, 225	R 8 622.00	NF250SVA...
		G1	30	22	22		250	R 9 547.00	NF250SVA250

Circuit Breakers V Series HVA / HGV

Type	Poles	Terminals	kA@			No. of Interphase Barriers	Rating (A)	Price Each excl. VAT	Order No.
			415 V	500 V	525 V				
NF63-HVA	3	G1	10	7.5	-	2	10,16,20,32,40,50,63	R 2 781.00	NF63HVA...
NF125-HVA	3	G2	50	35	22	2	16,20,32,40,50,63,80,100	R 6 835.00	NF125HVA...
NF125-HGVA*	3	G1	75	50	35	4	20-25,32-40,45-63,70-100,90-125	R 6 835.00	NF125HGVA...
NF160-HGVA*	3	G1	75	50	35	4	125-160	R 9 183.00	NF160HGVA125-160
NF250-HVA	3	G1	50	35	35	4	125,150,160,200,225	R 10 469.00	NF250HVA...
	3	G1	50	35	35	4	250	R 11 806.00	NF250HVA250
NF250-HGVA*	3	G1	75	50	35	4	175-250	R 11 806.00	NF250HGVA175-250

On Load Switch Disconnectors (Red Handle)

Type	Poles	Terminals	lcw kA	Sec.	No. of Interphase Barriers	Rating (A)	Price Each excl. VAT	Order No.
DSN125-SVA ¹	3	G1	4	1	2	125	R 2 776.00	DSN125SVA125
DSN250-SVA ¹	3	G1	4	1	4	250	R 6 667.00	DSN250SVA250
DSN250-CVA ²	3	G1	4	1	2	150	R 3 715.00	DSN250CVA150
DSN250-CVA ²	3	G1	4	1	4	250	R 6 174.00	DSN250CVA250

Notes:

- SVA backed up by suitable Short Circuit Protection Device (SCPD). Suitable up to 525 V.
- CVA only suitable up to 440 V

* Contact CBI for more information and availability

NOTE: Please fill in required AMP rating / range on dotted line of order number column

V-Series - Earth Leakage Circuit Breakers



NV125-SVA



NV250-SVA

Earth Leakage Circuit Breakers													D
Type	Poles	Terminals	kA@			Sensitivity mA Selectable	Time Delay	No. of Interphase Barriers	Rating (A)	Price Each excl. VAT	Order No.		
			380 V	415 V	480 V							525 V	550 V
NV63-HVA	3	G1	10	10	10	7.5	7.5	30,100,500	Inst	2	16,20,32,40,50,63	R 6 125.00	NV63HVA__
NV125-SVA	3	G1	25	25	15	18	10	30,175,250	Inst	2	16,20,32,40,50,63	R 8 243.00	NV125SVA__
	3	G1	25	25	15	18	10	30,175,250	Inst	2	80,100	R 8 746.00	NV125SVA__
NV125-HVA*	3	G1	50	50	30	22	18	30,175,250	Inst	2	16,20,32,40,50,63	R 16 217.00	NV125HVA__
	3	G1	50	50	30	22	18	30,175,250	Inst	2	80,100	R 16 217.00	
NV250-SVA	3	G1	25	25	15	18	10	30,250,375	Inst	4	125,150,175	R 12 561.00	NV250SVA__
	3	G1	25	25	15	18	10	30,250,375	Inst	4	200,225,250	R 14 112.00	NV250SVA__
NV250-SVA	3	G1	25	25	15	18	10	250,375,500	0.45,1,2	4	125,150,175	R 12 561.00	NV250SVA__TD
	3	G1	25	25	15	18	10	250,375,500	0.45,1,2	4	200,225,250	R 14 112.00	NV250SVA__TD
NV250-HVA	3	G1	50	50	30	22	18	30,250,375	Inst	4	150	R 30 426.00	NV250HVA150
	3	G1	50	50	30	22	18	30,250,375	Inst	4	175	R 30 426.00	NV250HVA175
	3	G1	50	50	30	22	18	30,250,375	Inst	4	200	R 30 426.00	NV250HVA200
	3	G1	50	50	30	22	18	30,250,375	Inst	4	225	R 30 426.00	NV250HVA225
NV250-HVA	3	G1	50	50	30	22	18	250,375,500	0.45,1,2	4	125	R 30 426.00	NV250HVA125TD
	3	G1	50	50	30	22	18	250,375,500	0.45,1,2	4	150	R 30 426.00	NV250HVA150TD
	3	G1	50	50	30	22	18	250,375,500	0.45,1,2	4	175	R 30 426.00	NV250HVA175TD
	3	G1	50	50	30	22	18	250,375,500	0.45,1,2	4	200	R 30 426.00	NV250HVA200TD
	3	G1	50	50	30	22	18	250,375,500	0.45,1,2	4	225	R 30 426.00	NV250HVA225TD

Only the left hand cavity is available for fitting of accessories

V-Series - MCCB Data



V-Series - Dimensions

Description	Dimensions (mm)		
	A	B	C
NF63 & NV63 (SVA / HVA)	75	130	68
NF125 & NV125 (SVA / HVA)	90	130	68
NF160 / 250 & NV250 (SVA / HVA)	105	165	68
DSN250 (SVA)	105	165	68
NF125 / 160 / 250 (HGVA)	105	165	68

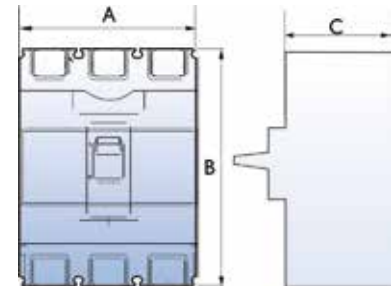

Thermal Adjustable Chart - HGVA

Type	Thermal ¹
NF125 HGVA 20 - 25 A	20 - 25
NF125 HGVA 32 - 40 A	32 - 40
NF125 HGVA 45 - 63 A	45 - 63
NF125 HGVA 70 - 100 A	70 - 100
NF125 HGVA 90 - 125 A	90 - 125
NF160 HGVA 125 - 160 A	125 - 160
NF250 HGVA 175 - 250 A	175 - 250

Notes:

1. Thermals are adjustable in fixed steps as per adjustability chart
Please fill in required AMP rating / range on dotted line of order number column

V-Series - Circuit Breakers DC Special use DC MCCBs

Circuit Breakers DC Locomotive Protection (Orange Handle) C

Type	Poles	Terminals	kA @ 440 Vdc *	No. of Interphase Barriers	Rating (A)	Price Each excl. VAT	Order No.
NF250-CVA (DC)	3	G1	10	4	150	R 5 137.00	NF250CVDC150
	3	G1	10	4	200	R 8 194.00	NF250CVDC200
	3	G1	10	4	250	R 8 194.00	NF250CVDC250

Note:

Also available with pre-fitted box terminals contact CBi

Circuit Breakers DC Locomotive Protection (Orange Handle) C

Type	Poles	Terminals	kA @ 440 Vdc *	No. of Interphase Barriers	Rating (A)	Price Each excl. VAT	Order No.
NF400-CWA (DC)	3	G4B	15	4	300	R 14 813.00	NF400CWDC300
	3	G4B	15	4	400	R 15 288.00	NF400CWDC400

Notes:

- NF250CVA: box terminal available as options 2 x per line / load (250 AF only)
Contact CBi for more information
- Magnetic settings at 50% of Standard MCCB
- Orange handle identification

* 400 Vdc using 3P in series
250 Vdc using 2P in series



V-Series - Accessories

Undervoltage Release C					
Type		Voltage Range	Std. Pack	Price Each excl. VAT	Order No.
NF / NV 63 HVA	LH/RH	24 Vac / dc	1	R 1 311.00	UVTNA024-05SVLS/RS
	LH/RH	48 Vac / dc	1	R 1 311.00	UVTNA048-05SVLS/RS
NF / NV 125 SVA / HVA / HGVA	LH/RH	110 Vac / dc	1	R 1 311.00	UVTNA130-05SVLS/RS
	LH/RH	220 - 250 Vac	1	R 1 311.00	UVTNA250-05SVLS/RS
NF / NV 250 SVA / HVA / HGVA	LH/RH	380 - 440 Vac	1	R 1 311.00	UVTNA480-05SVLS/RS
	LH/RH	500 / 600 Vac	1	R 1 311.00	UVTNA600-05SVLS/RS
DSN125 / 250					
Shunt Trip C					
NF / NV 63 HVA ** NF / NV 125 SVA / HVA HGVA NF / NV 250 SVA / HVA / HGVA DSN 125 / 250	LH/RH	24 - 48 Vac	1	R 624.00	SHTA048-05SVLS/RS
	LH/RH	100 - 240 Vac	1	R 624.00	SHTA240-05SVLS/RS
	LH/RH	380 - 550 Vac	1	R 624.00	SHTA550-05SVLS/RS
Auxiliary Switch C					
NF63 (SVA / HVA) (NV63 = LH) AX2-05SVLS (Double) NF / NV 125 SVA / HVA / HGVA NF / NV 250 SVA / HVA / HGVA DSN 125 / 250	LH		1	R 432.00	AX-05SVLS
	RH		1	R 432.00	AX-05SVRS
	LH		1	R 1 145.00	AX2-05SVLS
Alarm / Auxiliary Switch C					
NF63 (SVA / HVA) NF / NV 125 SVA / HVA / HGVA NF / NV 250 SVA / HVA / HGVA DSN 125 / 250	LH		1	R 889.00	ALAX-05SVLS
Terminal Covers (set) C					
NF63 & NV63 (SVA / HVA)			2	R 149.00	TCL-05SV3W
NF125 & NV125 (CVA / SVA / HVA)			2	R 365.00	TCL-1SV3W
NF160 / 250 & NV250 (CVA / SVA / HVA)			2	R 978.00	TCL-2SV3W
Extension Handles (Standard shaft 300 mm) C2					
NF63 / NV63 / NF125 / NV125 / DSN125 (SVA / HVA)			1	R 2 195.00	12MEC.1145
NF125HGVA / NF160HGVA / NF250HGVA & NV250 (CVA / SVA / HVA) DSN250			1	R 2 195.00	12MEC.1045
Motor Operator C					
NF125 (SVA / HVA)	100-240 Vac / 100-250 Vdc		1	R 17 456.00	MDS240-1SV ¹
NF250 (SVA / HVA)	100-240 Vac / 100-250 Vdc		1	R 17 456.00	MDS240-2SV ²
Handle Lockout C					
Description	Std. Pack			Price Each excl. VAT	Order No.
Handle lockout NV/NF 63/125	1			R 445.00	HLS-05SV
Handle lockout NV/NF 250/125	1			R 445.00	HLS-2SV
Stub Bar NF250HGVA & NV250 (CVA / SVA / HVA) DSN250 H2					
(G4B) Stub busbar (Qty 3)	Set			R 293.00	FSAX001

Notes:

- These units have mechanical trip indication on the operators
 - These units have electrical trip indication through an alarm switch
- * Contact CBI for availability
 ** NV only accessories for the left side only (LH)





Thermal-Magnetic Circuit Breakers (CWA) Compact Economy Class

Type	Poles	Terminals	kA@		No. of Interphase Barriers	Rating (A)	Price Each excl. VAT	Order No.
			400 V	500 V				
NF400-CWA	3	G4B	36	22	4	250	R 12 061.00	NF400CW250
		G4B	36	22	4	300	R 13 874.00	NF400CW300
		G4B	36	22	4	350, 400	R 14 545.00	NF400CW...
NF630-CWA	3	G4B	36	22	4	500, 630	R 22 561.00	NF630CW...

Note: Not certified for use at 525 / 550 V

Thermal-Magnetic Circuit Breakers (SWA) Standard Fixed Type

Type	Poles	Terminals	kA@			No. of Interphase Barriers	Rating (A)	Price Each excl. VAT	Order No.
			400 V	500 V	525 V				
NF400-SWA	3	G4B	50	40	35	4	250	R 16 202.00	NF400SW250
		G4B	50	40	35	4	300	R 16 339.00	NF400SW300
		G4B	50	40	35	4	350, 400	R 17 046.00	NF400SW...
NF630-SWA	3	G4B	50	40	35	4	500, 630	R 25 051.00	NF630SW...

Electronic Adjustable Circuit Breakers

Type	Poles	Terminals	kA@				No. of Interphase Barriers	Rating (A)	Price Each excl. VAT	Order No.
			380 V	400 V	500 V	525 V				
NF400-SEW	3	G4B	50	50	40	35	4	200-400	R 20 095.00	NF400SEW400
NF400-HEW	3	G4B	70	70	50	50	4	200-400	R 29 444.00	NF400HEW400
NF630-SEW	3	G4B	50	50	40	35	4	300-630	R 32 582.00	NF630SEW630
NF630-HEW	3	G4B	70	70	50	35	4	300-630	R 36 504.00	NF630HEW630
NF800-CEW	3	G4B	40	36	18	-	2	400-800	R 35 082.00	NF800CEW800
NF800-SEW	3	G4B	50	50	40	25	2	400-800	R 39 843.00	NF800SEW800
NF800-HEW	3	G4B	70	70	50	15	2	400-800	R 43 826.00	NF800HEW800

Electronic Adjustable Circuit Breakers

Type	Poles	Terminals	kA@			No. of Interphase Barriers	Rating (A)	Price Each excl. VAT	Order No.
			380 V	400 V	500 V				
NF1000-SEW	3	G4B	85	85	65	2	500-1000	R 44 877.00	NF1000SEW
NF1250-SEW	3	G4B	85	85	65	2	600-1250	R 53 603.00	NF1250SEW
NF1600-SEW	3	G4B	85	85	65	2	800-1600	R 77 471.00	NF1600SEW

On Load Switch Disconnectors (Red Handle)

Type	Poles	Terminals	lcw kA	Sec.	Rating (A)	Price Each excl. VAT	Order No.
DSN400-CWA	3	G4B	6	1	300, 400	R 9 486.00	DSN400CW...
DSN400-SWA	3	G4B	6	1	400	R 13 006.00	DSN400SW400
DSN630-CWA	3	G4B	8	1	630	R 15 957.00	DSN630CW630
DSN630-SWA	3	G4B	8	1	630	R 21 421.00	DSN630SW630
DSN800-CWA	3	G4B	10	1	800	R 22 156.00	DSN800CW800
DSN800-SWA	3	G4B	10	1	800	R 25 923.00	DSN800SW800
DSN1000-SW	3	G4B	15	1	1000	R 38 090.00	DSN1000SW
DSN1250-SW	3	G4B	15	1	1250	R 48 553.00	DSN1250SW

Notes:
Please fill in required AMP rating on dotted line of order number column
1. Backed up by suitable Short Circuit Protection Device (SCPD)

WSS - Earth Leakage Circuit Breakers and MCCB Data



Earth Leakage Circuit Breakers Progressive Super Series												D
Type	Poles	Terminals	kA@				Sensitivity mA Selectable	Time Delay	No. of Interphase Barriers	Rating (A)	Price Each excl. VAT	Order No.
			380 V	400 V	525 V	550 V						
NV400-SWA	3	G4B	50	50	15	15	100,300,500	0.45,1,2	4	250, 300, 350, 400	R 28 402.00	NV400SW...
NV400-SEW	3	G4B	50	50	15	15	100,300,500	0.45,1,2	4	200 - 400	R 30 522.00	NV400SEW400
NV630-SWA	3	G4B	50	50	25	15	100,300,500	0.45,1,2	4	500, 630	R 34 716.00	NV630SW....
NV800-SEW	3	G4B	50	50	25	15	100,300,500	0.45,1,2	2	400 - 800	R 39 283.00	NV800SEW800

WSS - Dimensions			
Description	Dimensions (mm)		
	A	B	C
NF400 & NV400 (CWA / SWA / SEW / HEW)	140	257	103
DSN400 (CWA / SWA)	140	257	103
NF630 & N630 (SEW / HEW)	140	257	103
NF630 & NV630 (CWA / SWA / SEW / HEW)	140	257	103
DSN630 (CWA / SWA)	140	257	103
NF800 & NV800 (CWA / SWA / SEW / HEW)	210	275	103
DSN800 (CWA / SWA)	210	275	103
NF1000 & NV1250 & NF1600 (SEW)	210	406	140
DSN1000 & DSN1250 (SW)	210	406	140

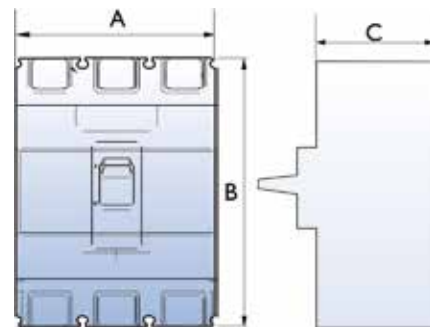

WSS - Circuit Setting Range (Adjustable Breakers)		
Type	Rating (A)	Setting Range (fixed and variable steps)
NF400-SEW (CEW / SEW / HEW)	200 - 400	200 / 225 / 250 / 300 / 350 / 400 A
NF630-SEW (CEW / SEW / HEW)	300 - 630	300 / 350 / 400 / 500 / 600 / 630 A
NF800-SEW (CEW / SEW / HEW)	400 - 800	400 / 450 / 500 / 600 / 700 / 800 A
NF1000-SEW	500 - 1000	500 / 600 / 700 / 800 / 900 / 1000 A
NF1250-SEW	600 - 1250	600 / 700 / 800 / 1000 / 1200 / 1250 A
NF1600-SEW	800 - 1600	800 / 1000 / 1200 / 1400 / 1500 / 1600 A



Undervoltage Release C

Type		Voltage Range	Std. Pack	Price Each excl. VAT	Order No
NF400 / 630 / 800 (NV400 / 630 / 800 = LH) (CW / SW / CEW / SEW / HEW)	RH	24 - 48 Vdc	1	R 3 715.00	UVTSD048-8SWRFS
	LH/RH	110 Vdc	1	R 3 715.00	UVTD110-4SWS
	LH/RH	110 - 120 Vac	1	R 2 275.00	UVTA120-4SWS
	LH/RH	220 - 240 Vac	1	R 2 275.00	UVTA240-4SWS
	LH/RH	380 - 415 Vac	1	R 2 275.00	UVTA415-4SWS
	LH/RH	500 - 550 Vac	1	R 2 275.00	UVTA550-4SWS
NF1000SEW & NF1250SEW & NF1600SEW	RH	100 - 120 Vac	1	R 3 353.00	UVTNA130-10SWRS
	RH	200 - 240 Vac	1	R 3 353.00	UVTNA240-10SWRS
	RH	380 - 450 Vac	1	R 3 353.00	UVTNA450-10SWRS
	RH	500 - 550 Vac	1	R 3 353.00	UVTNA550-10SWRS

Shunt Trip¹ C

NF400 / 630 / 800 (CW / SW / CEW / SEW / HEW) (NV400 / 630 / 800 = LH)	RH	24 - 48 Vac / Vdc	1	R 2 126.00	SHT48-4SWRS
	LH	100-450 Vac / 100-200 Vdc	1	R 1 264.00	SHT-4SWLS
	RH	100-450 Vac / 100-200 Vdc	1	R 1 264.00	SHT-4SWRS
	RH	380 - 550 Vac	1	R 1 264.00	SHTA550-4SWRS
NF1000SEW & NF1250SEW & NF1600SEW	RH	24 Vac	1	R 3 198.00	SHTA024-10SWRS
	RH	48 Vac	1	R 3 198.00	SHTA048-10SWRS
	RH	100 - 120 Vac	1	R 3 198.00	SHTA120-10SWRS
	RH	200 - 240 Vac	1	R 3 198.00	SHTA240-10SWRS
	RH	380 - 450 Vac	1	R 3 198.00	SHTA450-10SWRS
	RH	500 - 550 Vac	1	R 3 198.00	SHTA550-10SWRS

Auxiliary Switch C

NF400 / 630 / 800 (CW / SW / CEW / SEW / HEW)	LH		1	R 822.00	AX-4SWLS
	RH		1	R 822.00	AX-4SWRS
Double Auxiliary	LH		1	R 1 081.00	AX2-4SWLS
NF1000SEW & NF1250SEW & NF1600SEW	LH		1	R 1 142.00	AX-10SWLS
	RH		1	R 1 142.00	AX-10SWRS

Alarm / Auxiliary Switch C

NF400 / 630 / 800 & NV400 / 630 / 800	LH		1	R 1 074.00	ALAX-4SWLS
NF1000SEW & NF1250SEW & NF1600SEW	LH		1	R 1 889.00	ALAX-10SWLS

Motor Operator * C

NF400 / 630 & NV400 / 630 (CW / SW / CEW / SEW / HEW)		200 - 220 Vac	1	R 11 058.00	MDS-4SWA220
NF800 & NV800 (CEW / SEW / HEW)		200 - 220 Vac	1	R 11 058.00	MDS-8SWA220
NF1000SEW & NF1250SEW & NF1600SEW		200 - 220 Vac	1	R 57 348.00	MD-10SWA220

Keylocks H2

KD Cylindrical Lock GP (same keys) NV400 to NV800 / DSN400 to DSN1250	RH		1	R 994.00	4470113
KD Cylindrical Lock WD (different keys) NV400 to NV800 / DSN400 to DSN1250	RH		1	R 994.00	4470112

Notes:

- For shunt trip possibly on NV breaker, contact CBI
- * Contact CBI for availability

WSS - Accessories



Terminal Covers *				C
Type	Std. Pack	Price Each excl. VAT	Order No.	
NF400 / 630 & NV400 / 630 (CW / SW / CEW / SEW / HEW)	1	R 1 110.00	TCL-4SW3	
NF800 & NV800 (CEW / SEW / HEW)	1	R 1 387.00	TCL-8SW3	
NFI000SEW & NF1250SEW	1	R 2 156.00	TCL-10SW3	
Handle Locking Device (Metal)				C
NF400 / 630 & NV400 / 630 (CW / SW / CEW / SEW / HEW)	1	R 558.00	HLS-4SW	
NF1000 / 1250 1600 SEW	1	R 3 923.00	HLS-10SW	
Extension Handles				C2
NF400 / 630 & NV400 / 630 (CW / SW / CEW / SEW / HEW)	(Std. shaft - 300 mm)	1	R 2 349.00	12MEC.0645
NF800 & NV800 (CEW / SEW / HEW)	(Std. shaft - 300 mm)	1	R 3 053.00	12MEC.0845
NF1000SEW & NF1250SEW & NF1600SEW	(Std. shaft - 300 mm)	1	R 3 923.00	12MEC.0945

Note:

* Contact CBI for availability

AE World Super Series Low Voltage Air Circuit Breakers (CIF Approved)



AE1600-SW



Air Circuit Breakers¹ C1

Type	Poles	Terminals	kA@		Std Pack	Rating (A)	Price Each excl. VAT Fixed (F) ³	Price Each excl. VAT Draw out (D) ³	Order No.
			415 / 500 / 525 V	550 / 600 / 690 V					
AE630-SW	3	Horizontal	65	65	1	315 - 630	R 53 514.00	R 72 467.00	AE630SW(F/D)
AE1000-SW	3	Horizontal	65	65	1	500 - 1000	R 56 245.00	R 76 248.00	AE1000SW(F/D)
AE1250-SW	3	Horizontal	65	65	1	625 - 1250	R 59 211.00	R 77 700.00	AE1250SW(F/D)
AE1600-SW	3	Horizontal	65	65	1	800 - 1600	R 62 526.00	R 79 155.00	AE1600SW(F/D)
AE2000-SW	3	Horizontal	85	75	1	1000 - 2000	R 74 442.00	R 97 464.00	AE2000SW(F/D)
AE2500-SW	3	Horizontal	85	75	1	1250 - 2500	R 85 897.00	R 103 104.00	AE2500SW(F/D)
AE3200-SW	3	Horizontal	85	75	1	1600 - 3200	R 108 334.00	R 128 796.00	AE3200SW(F/D)
AE4000-SWA	3	Vertical	75	75	1	2000 - 4000	R 173 863.00	R 211 781.00	AE4000SWA(F/D)

AE World Super Series Low Voltage Switch Disconnectors

Switch Disconnectors² C1

Type	Poles	Terminals	Std. Pack	Rating (A)	Price Each excl. VAT Fixed (F) ³	Price Each excl. VAT Draw out (D) ³	Order No.
DSN 1600-SW	3	Horizontal	1	1600	R 53 397.00	R 69 791.00	DSN1600SW(F/D)
DSN 2000-SW	3	Horizontal	1	2000	R 66 498.00	R 92 330.00	DSN2000SW(F/D)
DSN 2500-SW	3	Horizontal	1	2500	R 75 722.00	R 92 986.00	DSN2500SW(F/D)
DSN 3200-SW	3	Horizontal	1	3200	R 95 836.00	R 116 360.00	DSN3200SW(F/D)
DSN 4000-SWA*	3	Vertical	1	4000	R 157 032.00	R 191 255.00	DSN4000SWA(F/D)

Notes:

For Mitsubishi ACBs with required amperages of 4 000 A, 5 000 A and 6 000 A, contact CBi for price and availability. Contact CBi for all technical information and stock availability for ACBs and accessories.

- All Mitsubishi ACB units come complete with the following:
 - Terminal Block
 - Standard auxiliary 2A / 2B
 - Safety Shutters on cradle – fixed or draw-out type, as well as on DSN type.
 - Electronic Trip Relay (ETR) – WS-1 standard unit.
 Other accessories and auxiliaries are to be ordered separately.
- All Mitsubishi ACB switch disconnectors (DSN) come complete with the following:
 - Terminal Block
 - Standard auxiliary 2A / 2B
 - Safety Shutters on cradle – fixed or draw-out type, as well as on DSN type.
 Other accessories and auxiliaries are to be ordered separately.
- Ordering information numbers:
 - Fixed mount type = (F)
 - Draw out mount type = (D)

* Contact CBi for availability

World Super Series Accessories - Air Circuit Breakers Type AE630-SW to AE4000-SWA C1

Type	Voltage AC	Voltage DC	Std. Pack	Price Each excl. VAT	Order No.
Door interlock* for all Draw out types	-	-	1	R 8 611.00	WS-DI-SAED
Door interlock* for all Fixed out types	-	-	1	R 9 264.00	WS-DI-SAEF
Cell Switch* (4 Contacts)	-	-	1	R 5 146.00	WS-CLCCELLS
Auxiliary Switch (5N/O + 5N/C)	-	-	1	R 3 292.00	WS-AXAESW5A5B
Shunt trip	100 - 250	100 - 250	1	R 2 337.00	WS-SHTAE110AC
Shunt trip*	-	24 - 48	1	R 2 337.00	WS-SHTAE24DC
Shunt trip	380 - 525	-	1	R 2 337.00	WS-SHTAE400AC
Motor charging device	100 - 125	100 - 125	1	R 6 991.00	WS-MDAESW110
Motor charging device	200 - 250	200 - 250	1	R 6 991.00	WS-MDAESW220
Closing coil unit	100 - 250	100 - 250	1	R 2 930.00	WS-CCAEO25A
Closing coil unit	-	24 - 48	1	R 3 701.00	WS-CCAEO048A
Cylinder lock mechanism with viro key (factory-fitted)	-	-	1	R 3 919.00	WS-CYLAESW
Counter*	-	-	1	R 3 919.00	WS-CNTAESW
Undervoltage tripping device instantaneous (tripping coil included)	100 - 120	-	1	R 8 232.00	WS-UVT-A120-INS
Undervoltage tripping device instantaneous (tripping coil included)	200 - 240	-	1	R 8 232.00	WS-UVT-A240-INS
Undervoltage tripping device time delay (tripping coil included)	200 - 240	-	1	R 8 232.00	WS-UVT-A240-TD3
Undervoltage tripping device instantaneous (tripping coil included)	380 - 460	-	1	R 13 276.00	WS-UVT-A460-INS
Push button cover (for padlocking)	-	-	1	R 520.00	WS-BCL-SAE
Terminal connectors on breakers	-	-	1	R 2 237.00	WS-ATC-SAEBKR
Terminal connectors on cradle	-	-	1	R 2 237.00	WS-ATC-SAECL
Ground fault protection relay* (module must be fitted to ETR)	-	-	1	R 2 577.00	WS-G1
MCR Switch high inrush blocking	-	-	1	R 2 126.00	WS-MCR
Mechanical interlock device (draw out type only) (630SW,1000SW, 1250SWA, 1600SWA)	-	-	1	R 6 991.00	WS-MIAESW16D
Mechanical interlock device (fixed type only) (630SW,1000SW, 1250SWA, 1600SWA)	-	-	1	R 6 991.00	WS-MIAESW16F
Mechanical interlock device (draw out type only) (2000SW-3200SW,4000SWA)	-	-	1	R 6 991.00	WS-MIAESW32D
Mechanical interlock device (fixed type only) (2000SW-3200SW, 4000SWA)	-	-	1	R 6 991.00	WS-MIAESW32F
Mechanical interlock wire set* (used when 3 ACBs are interlocked)	-	-	1	R 3 450.00	WS-MI-IW
Shutter locking parts* (padlock excluded)	-	-	1	R 261.00	WS-SSTAESW
Safety shutter (AE630SW - AE1600SW, AE2000SWA)	-	-	1	R 2 177.00	WS-SSTAESW160
Safety shutter (AE2000SW - AE3200SW, AE4000SWA)	-	-	1	R 2 177.00	WS-SSTAESW400
Cradle* (AE630SW - AE1600SW) - (Safety shutters) included	-	-	1	R 13 348.00	WS-AE1600SSCR
Cradle* (AE2000SW - AE2500SW) - (Safety shutters) included	-	-	1	R 21 529.00	WS-AE2000SSCR
Cradle* (AE3200SW) (safety shutters) included	-	-	1	R 21 529.00	WS-AE3200SSCR
Vertical terminal adaptor* (Draw out) set of 3 (AE630SW-AE1600SW)	-	-	1	R 5 789.00	WS-VTA-02SAC
Vertical terminal adaptor* (Draw out) set of 3 (AE2000SW-AE2500SW)	-	-	1	R 10 218.00	WS-VTA-03SAC
Vertical terminal adaptor* (Draw out) set of 3 (AE3200SW)	-	-	1	R 12 255.00	WS-VTA-32SAE
Extension module (EX1)* (compulsory module for display and interface function)	-	-	1	R 6 526.00	WS-EX1
Display module (DP1)* (WS - EX1 is required)	-	-	1	R 7 208.00	WS-DISPLAY
VT Unit (VT)* (WS-EX1 is required)	-	-	1	R 4 633.00	WS-VT
CC - Link interface unit* (WS - EX1 is required)	-	-	1	R 12 864.00	WS-BIF-CC
Draw out position switch for network* (WS-BIF-IO is required)	-	-	1	R 4 120.00	WS-BIF-DO-POS
I/O Unit* (interface unit is required ex WS-BIF-PR)	-	-	1	R 6 176.00	WS-BIF-IO
PROFIBUS-DP Interface unit* (WS-EX1 is required)	-	-	1	R 12 864.00	WS-BIF-PR
Modbus interface unit* (WS-EX1 is required)	-	-	1	R 12 864.00	WS-BIF-MD
Neutral pole current transformer* (AE1600SW)	-	-	1	R 4 898.00	WS-NCTAESW16
Neutral pole current transformer* (AE2000SW, AE2000SWA)	-	-	1	R 4 898.00	WS-NCTAESW20
Neutral pole current transformer* (AE3200SW)	-	-	1	R 6 531.00	WS-NCTAESW32

* Contact CBI for availability

**Mitsubishi Series ST / SN
AC Contactor, AC Coil ST + SN**



Magnetic Contactors Series ST and SN											K
Type ²	Rated Continuous Current	AC-1		AC-3		AC-4		Standard Aux Contacts ¹		Price Each excl. VAT	Order No.
		380 V / 440 V (A)	525 V (A)	380 V / 440 V kW (A)	525 V kW (A)	380 V / 440 V kW (A)	525 V kW (A)	Normally Open	Normally Closed		
ST10	20	11	8	4 (9)	4 (7)	2.2 (6)	2.7 (6)	1	-	R 647.00	ST10__
ST12	20	13	11	5.5 (12)	5.5 (9)	4 (9)	5.5 (9)	1	1	R 890.00	ST12__
ST20	25	20	16	7.5 (18)	7.5 (17)	5.5 (13)	5.5 (10)	1	1	R 1 069.00	ST20__
ST21	32	32	32	11 (23)	11 (17)	5.5 (13)	5.5 (10)	2	2	R 1 449.00	ST21__
ST25	32	32	32	15 (30)	15 (24)	7.5 (17)	7.5 (12)	2	2	R 1 802.00	ST25__
ST35	60	60	60	18.5 (40)	18.5 (32)	11 (24)	11 (17)	2	2	R 2 319.00	ST35__
ST50	80	80	80	22 (50)	25 (38)	15 (32)	15 (24)	2	2	R 2 970.00	ST50__
ST65	100	100	100	30 (65)	37 (60)	22 (47)	22 (38)	2	2	R 3 655.00	ST65__
ST80	120	120	120	45 (85)	45 (75)	30 (62)	30 (45)	2	2	R 5 427.00	ST80__
ST100	150	150	150	55 (105)	55 (85)	37 (75)	37 (55)	2	2	R 6 960.00	ST100__
SN125	150	150	150	60 (120)	60 (90)	22 (90)	22 (90)	2	2	R 7 847.00	SN125__
SN150	200	200	200	75 (150)	90 (140)	30 (110)	37 (80)	2	2	R 11 439.00	SN150__
SN180	260	260	260	90 (180)	110 (180)	37 (150)	45 (140)	2	2	R 12 954.00	SN180__
SN220	260	260	260	132 (250)	132 (200)	45 (180)	55 (140)	2	2	R 14 709.00	SN220__
SN300	350	350	350	160 (300)	160 (250)	60 (220)	60 (200)	2	2	R 26 919.00	SN300__
SN400	450	450	450	220 (400)	225 (350)	75 (300)	90 (250)	2	2	R 34 459.00	SN400__
SN600	800	660	660	330 (630)	330 (500)	110 (400)	130 (350)	2	2	R 47 802.00	SN600__
SN800	1000	800	800	440 (800)	500 (720)	130 (630)	150 (500)	2	2	R 61 459.00	SN800__

Notes:

DIN rail mounting for all contactors up to ST-65

1. Extra auxiliary contact blocks can be added (refer to contactor spares and accessories)
2. When ordering please specify coil voltage e.g. ST10-400

These units have finger protection on terminals as standard

Standard coil voltages are 110 V, 220 V, 400 V and 525 V

Insulation Voltage / V _{ins} : 690 V
Impulse Withstand / V _{imp} : 6 kV
Poles: 3
Note: Ratings based on 1 x 10 ⁶ operations

Contactor Utilisation Categories (IEC 60947-4)	
Alternating Current	
AC-1	All AC loads with a power factor ≥ 0.80 • heating resistive load
AC-3	Starting and stopping squirrel cage motors • starting ± 7 times rated motor current • stopping the voltage is at ± 20% of mains supply voltage • lighting load
AC-4	Plugging and inching of squirrel cage • closing and operating at ± 7 times rated motor current • severe braking
AC-15	Control loads (72 VA) Aux contact ratings AC
Direct Current	
DC-13	Aux contact ratings DC



Mitsubishi Accessories



Accessories													K
Order No	Mechanical Interlock					Front Clip-on Aux Contact Block		Side Clip-on Aux Contact Block		Side Clip-on Aux Contact Block			
	UTML11	UTML21	UTML80	UNML150	UNML220	UTAX2 (1A,1B) UTAX2CX2A (2A) UTAX2CX2B (2B)	UTAX4 (2A,2B) UTAX4CX3A (3A,1B) UTAX4CX4A (4A)	UNAX11 (1A, 1B)	UTAX11 (1A,1B)	UNAX80 (1A,1B)	UNAX150 (1A,1B)	UNAX600 (2A,2B)	
Type	Price Each excl. VAT												
ST10	R 760.00	-	-	-	-	R 363.00	R 477.00	-	R 492.00	-	-	-	
ST12	R 760.00	-	-	-	-	R 363.00	R 477.00	-	R 492.00	-	-	-	
ST20	R 760.00	-	-	-	-	R 363.00	R 477.00	-	R 492.00	-	-	-	
ST21	-	R 974.00	-	-	-	R 363.00	R 477.00	-	R 492.00	-	-	-	
ST25	-	R 974.00	-	-	-	R 363.00	R 477.00	-	R 492.00	-	-	-	
ST35	-	R 974.00	-	-	-	R 363.00	R 477.00	-	R 492.00	-	-	-	
ST50	-	R 974.00	-	-	-	R 363.00	R 477.00	-	R 492.00	-	-	-	
ST65	-	R 974.00	-	-	-	R 363.00	R 477.00	R 492.00	-	-	-	-	
ST80	-	R 974.00	-	-	-	-	-	R 492.00	-	-	-	-	
ST100	-	-	R 942.00	-	-	-	-	-	-	R 476.00	-	-	
SN125	-	-	R 942.00	-	-	-	-	-	-	R 476.00	-	-	
SN150	-	-	-	R 1 247.00	-	-	-	-	-	-	R 510.00	-	
SN180	-	-	-	-	R 1 247.00	-	-	-	-	-	R 510.00	-	
SN220	-	-	-	-	R 1 247.00	-	-	-	-	-	R 510.00	-	
SN300	-	-	-	-	R 1 247.00	-	-	-	-	-	R 510.00	-	
SN400	-	-	-	-	R 1 247.00	-	-	-	-	-	R 510.00	-	
SN600	-	-	-	-	-	-	-	-	-	-	-	R 3 615.00	
SN800	-	-	-	-	-	-	-	-	-	-	-	R 3 615.00	

Notes:

A N/O - Normally open contacts
B N/C - Normally closed contacts



**Mitsubishi Series THT / THN
Thermal Overload Relays 3 Element Heater Type**



THT Range

Type	Contactor Size	Mid Set Amps	Nominal Range Amps	Price Each excl. VAT
THT18KP ¹				K
THT18-0.17	ST10 ST12 ST20	0.17 A	0.14 A to 0.22 A	R 558.00
THT18-0.24		0.24 A	0.2 A to 0.32 A	R 558.00
THT18-0.35		0.35 A	0.28 A to 0.42 A	R 558.00
THT18-0.5		0.5 A	0.4 A to 0.6 A	R 558.00
THT18-0.7		0.7 A	0.55 A to 0.85 A	R 558.00
THT18-0.9		0.9 A	0.7 A to 1.1 A	R 558.00
THT18-1.3		1.3 A	1.0 A to 1.6 A	R 558.00
THT18-1.7		1.7 A	1.4 A to 2.0 A	R 558.00
THT18-2.1		2.1 A	1.7 A to 2.5 A	R 558.00
THT18-2.5		2.5 A	2.0 A to 3.0 A	R 558.00
THT18-3.6		3.6 A	2.8 A to 4.4 A	R 558.00
THT18-5		5 A	4.0 A to 6.0 A	R 558.00
THT18-6.6		6.6 A	5.2 A to 8.0 A	R 558.00
THT18-9		9 A	7.0 A to 11.0 A	R 558.00
THT18-11		11 A	9.0 A to 13.0 A	R 558.00
THT18-15	15 A	12.0 A to 18.0 A	R 558.00	
THT25KP ²				K
THT25-0.24	ST21 ST25 ST35 ST50	0.24 A	0.2 A to 0.32 A	R 722.00
THT25-0.35		0.35 A	0.28 A to 0.42 A	R 722.00
THT25-0.5		0.5 A	0.4 A to 0.6 A	R 722.00
THT25-0.7		0.7 A	0.55 A to 0.85 A	R 722.00
THT25-0.9		0.9 A	0.7 A to 1.1 A	R 722.00
THT25-1.3		1.3 A	1.0 A to 1.6 A	R 722.00
THT25-1.7		1.7 A	1.4 A to 2.0 A	R 722.00
THT25-2.1		2.1 A	1.7 A to 2.5 A	R 722.00
THT25-2.5		2.5 A	2.0 A to 3.0 A	R 722.00
THT25-3.6		3.6 A	2.8 A to 4.4 A	R 722.00
THT25-5		5 A	4.0 A to 6.0 A	R 722.00
THT25-6.6		6.6 A	5.2 A to 8.0 A	R 722.00
THT25-9		9 A	7.0 A to 11.0 A	R 722.00
THT25-11		11 A	9.0 A to 13.0 A	R 722.00
THT25-15		15 A	12.0 A to 18.0 A	R 722.00
THT25-22	22 A	18.0 A to 26.0 A	R 722.00	

Notes:

1. For direct connection to contactors
2. THT25 and THT50 need connecting links sold separately for direct connections to contactors, refer to contactor accessories page



Mitsubishi Series THT / THN Thermal Overload Relays 3 Element Heater Type



Type	Contactor Size	Mid Set Amps	Nominal Range Amps	Price Each excl. VAT
THT50KP ¹				K
THT50-29	ST35 ST50	29 A	24 A to 34 A	R 724.00
THT50-35		35 A	30 A to 40 A	R 724.00
THT50-42		42 A	34 A to 50 A	R 724.00
THT65KP				K
THT65-15	ST65 ST80	15 A	12 A to 18 A	R 1 207.00
THT65-22		22 A	18 A to 26 A	R 1 207.00
THT65-29		29 A	24 A to 34 A	R 1 207.00
THT65-35		35 A	30 A to 40 A	R 1 207.00
THT65-42		42 A	34 A to 50 A	R 1 207.00
THT65-54		54 A	43 A to 65 A	R 1 207.00
THT100KP				K
THT100-67	ST80 ST100	67 A	54 A to 80 A	R 1 207.00
THT100-82		82 A	65 A to 100 A	R 1 207.00
THT100-95		95 A	85 A to 105 A	R 1 207.00
THN120KP				K
THN120-42	SN125 SN150	42 A	34 A to 50 A	R 1 779.00
THN120-54		54 A	43 A to 65 A	R 1 779.00
THN120-67		67 A	54 A to 80 A	R 1 779.00
THN120-82		82 A	65 A to 100 A	R 1 779.00
THN120TAKP				K
THN120-105	SN125 SN150	105 A	85 A to 125 A	R 1 779.00
THN120-125		125 A	100 A to 150 A	R 1 779.00
THN220RHKP				K
THN220-82	SN180 SN220	82 A	65 A to 100 A	R 4 846.00
THN220-105		105 A	85 A to 125 A	R 4 846.00
THN220-125		125 A	100 A to 150 A	R 4 846.00
THN220-150		150 A	120 A to 180 A	R 4 846.00
THN220-180		180 A	140 A to 200 A	R 4 846.00
THN220-210		210 A	170 A to 250 A	R 4 846.00
THN400RHKP ²				K
THN400-150	SN300 SN400	150 A	120 A to 180 A	R 6 197.00
THN400-180		180 A	140 A to 220 A	R 6 197.00
THN400-250		250 A	200 A to 300 A	R 6 197.00
THN400-330		330 A	260 A to 400 A	R 6 197.00

Notes:

1. THT25 and THT50 need connecting links sold separately for direct connections to contactors, refer to contactor accessories page
2. Connecting links included. For contactor size SN220 only.



Accessories



Connecting Links for THN Overloads & SN + ST Contactors		K
Type	Contacteur Size	Price Each excl. VAT
UN-TH21	Connecting links THT25 & ST21 / ST25	R 252.00
UT-TH50	Connecting links THT25/THT50 & ST35 / ST50	R 294.00
4370000	Connecting links THT100 & ST100+Bracket	R 349.00
4370006	Connecting links THT65/THT100 & ST65 / ST80	R 272.00
BH579N355	Connecting links THN120KP & SN125	R 400.00
BH589N355	Connecting links THN120TAKP & SN150	R 400.00
UT-HZ18	Adaptor block for separate mounting of THT18	R 511.00
UN-TH25	UN-TH25 connecting links	R 293.00

Notes:

THT25 and THT50 need connecting links sold separately for direct connections to contactors, refer to contactor accessories page



Mitsubishi Series ETN



ETN Range

Electronic Motor Protection Relays Type ETN				K2
Type	Control Voltage	Setting Range	Std. Pack	Price Each excl. VAT
ETN60				K2
ETN60-1-110 or 220	110 / 220 V	0.25 A to 1 A	1	R 4 107.00
ETN60-4-110 or 220		1 A to 4 A	1	R 4 107.00
ETN60-8-110 or 220		2 A to 8 A	1	R 4 107.00
ETN60-20-110 or 220		5 A to 20 A	1	R 4 107.00
ETN60-60-110 or 220		15 A to 60 A	1	R 4 107.00
ETN150				K2
ETN150-110 or 220	110 / 220 V	40 A to 150 A	1	R 8 469.00
ETN150-400 or 525	400 / 525 V	40 A to 150 A	1	R 9 520.00
ETN360				K2
ETN360-110 or 220	110 / 220 V	110 A to 360 A	1	R 8 799.00
ETN360-400 or 525	400 / 525 V	110 A to 360 A	1	R 9 799.00

Remote Reset			K2
Type	Item Description	Std. Pack	Price Each excl. VAT
Remote Reset	Remote reset for ETN	1	R 250.00

Notes:
 Motor protection relays type ETN feature selectable protection mode, i.e. overload, phase reversal protection with selectable tripping time 600 % of setting
 Remote Reset available on request, factory-fitted only - contact CBI for availability



Mitsubishi Series SH-V

	SH-V160	SH-V320	SH-V400	SH-V600
A	210 mm			290 mm
B	210 mm			285 mm
C	210 mm			225 mm

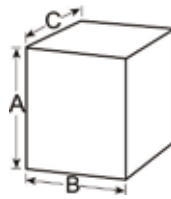

Medium Voltage Vacuum Contactors Series SH-V up to 1500 V									K1
Type ¹	AC-1	AC-3				Coil Voltage (V)	Standard Aux Contacts		Price Each excl. VAT
	Lth (A)	440 V kW (A)	660 V kW (A)	1000 V kW (A)	1500 V kW (A)		Normally Open	Normally Closed	
SH-V160	200	110 (180)	160 (180)	225 (160)	315 (160)	STD: 110 / 220 / 400 / 525	2	2	R 49 512.00
SH-V320	350	200 (320)	315 (320)	450 (320)	700 (320)	STD: 110 / 220 / 400 / 525	2	2	R 49 512.00
SH-V400	450	250 (400)	400 (400)	550 (400)	800 (400)	STD: 110 / 220 / 400 / 525	2	2	R 54 186.00
SH-V600	750	300 (630)	600 (600)	750 (600)	1000 (600)	STD: 110 / 220 / 400 / 525	2	2	R 98 166.00

Note:

- Specify coil voltages

Spares and Accessories

Type *	Order No.	Vacuum Tube Assembly (Set of 3)			Coils		K1
		SHV320TUBE	SHV400TUBE	SHV600TUBE	SN180__C ¹ SHV160/320/400	SN300__C ² SHV600	
		Price Each excl. VAT			Price Each excl. VAT		
SH-V160		-	-	-	R 3 264.00		
SH-V320		R 30 415.00	-	-	R 3 264.00		
SH-V400		-	R 30 415.00	-	R 3 264.00		
SH-V600		-	-	R 32 015.00		R 4 292.00	

Notes:

* Contact CBI for availability

A = Normal Open Contact
B = Normal Closed Contact

- SH-V coils interchangeable with SN180 coils
- SH-V coils interchangeable with SN300 coils



Mitsubishi Series VZ

Series VZ	
A	367 mm
B	361 mm
C	238 mm

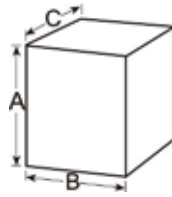

Medium Voltage Vacuum Contactors Series VZ (Std. 2 No / 2NC Contactor)										K4
Type ^{1 & 2}	Lth (A)	3 Ph. Induction Motor Rating				Transformer Rating				Price Each excl. VAT
		3.3 kV kW	3.3 kV (A)	6.6 kV kW	6.6 kV (A)	3.3 kV kW	3.3 kV (A)	6.6 kV kW	6.6 kV (A)	
VZ2-PE-E10 (110 Vac / Vdc)	200	35 to 75	20	75 to 160	20	5 / 10	0.87 / 1.75	5 / 10	0.44 / 0.87	R 64 515.00
	200	90 to 200	50	185 to 400	50	20 / 30	3.5 / 5.25	20 / 30	1.75 / 2.62	
	200	220 to 400	100	450 to 800	100	50 / 75	8.75 / 13.1	50 / 75	4.37 / 6.56	
	200	450 to 630	150	900 to 1250	150	100 / 150	17.5 / 26.2	100 / 150	8.75 / 13.1	
	200	710 to 750	200	1500	200	200 / 300	35.0 / 52.5	200 / 300	17.5 / 26.2	
	200	-	-	-	-	500 / 750	87.5 / 13.1	500 / 750	43.7 / 65.6	
	200	-	-	-	-	1000	175	1000 / 1500	87.5 / 131	
	200	-	-	-	-	-	-	2000	175	
VZ4-PE-E10 (110 Vac / Vdc)	400	900 to 1250	300	2500	300	1500	262	3000	262	R 88 044.00
	400	1500	400	3000	400	2000	350	4000	350	
VZ2-PE-E20 (220 Vac / Vdc)	200	35 to 75	20	75 to 160	20	5 / 10	0.87 / 1.75	5 / 10	0.44 / 0.87	R 67 699.00
	200	90 to 200	50	185 to 400	50	20 / 30	3.5 / 5.25	20 / 30	1.75 / 2.62	
	200	220 to 400	100	450 to 800	100	50 / 75	8.75 / 13.1	50 / 75	4.37 / 6.56	
	200	450 to 630	150	900 to 1250	150	100 / 150	17.5 / 26.2	100 / 150	8.75 / 13.1	
	200	710 to 750	200	1500	200	200 / 300	35.0 / 52.5	200 / 300	17.5 / 26.2	
	200	-	-	-	-	500 / 750	87.5 / 13.1	500 / 750	43.7 / 65.6	
	200	-	-	-	-	1000	175	1000 / 1500	87.5 / 131	
	200	-	-	-	-	-	-	2000	175	
VZ4-PE-E20 (220 Vac / Vdc)	400	900 to 1250	300	2500	300	1500	262	3000	262	R 92 189.00
	400	1500	400	3000	400	2000	350	4000	350	

(All accessories are factory-fitted only)

Addition of Auxiliary Contacts

Description of Additional Contactors that may be fitted to the Standard Products			K4
Type	Description	Price Each excl. VAT	
VZMOD1	Additional 2N/O and 2N/C contacts with external pre-wired terminal plug	R 6 293.00	
VZMOD2 (110 Vac)	Additional 4N/O and 4N/C contacts with external pre-wired terminal plug	R 9 913.00	
VZMOD3 (220 Vac)	Additional 2N/O and 2N/C contacts with external pre-wired terminal plug	R 9 913.00	

Notes:

1. Available coil voltages are:

- 110 Vac
- 220 Vac

VZ2 = 200 A

VZ4 = 400 A

E10 = 110 Vac / Vdc control

E20 = 220 Vac / Vdc control

2. Standard aux contacts fitted are 2N/O and 2N/C

Aux contact ratings are 1 A @ 220 Vac and 110 Vdc

Extra aux contacts can be fitted

All accessories are factory-fitted only



Terminal Blocks

Terminal Blocks							E
Type	Current Rating (A) Normal vs Max	No. of Ways	Rated Voltage	Dielectric Strength (6 sec)	Max Wire Size mm ²	Torque Nm	Price Each excl. VAT
SafeTek15-3	15 (16)	3	600 Vac	2500 Vac	2.5	0.5 - 1.0	R 45.00
SafeTek30-3	30 (40)	3			6	1.4 - 2.0	R 60.00
SafeTek60-1	60 (70)	1			16	2.5 - 3.5	R 38.00
SafeTek80-1	80 (94)	1			25	4.0 - 5.5	R 67.00
SafeTek120-1	120 (132)	1			35 - 70	0.5 - 1.0	R 103.00
SafeTek200-1	200 (240)	1			95 - 120	10 - 12	R 174.00
SafeTek400-1	370 (400)	1			180 - 240	21 - 28	R 466.00
Endcap-High						3.8 - 4.5	R 13.00
Endcap-Low						0.5 - 1.0	R 5.00

Notes:

Contact CBI for availability
Order number = type number

Safetek Adaptive Terminals

- Touch protected
- DIN rail mounting (35 mm)
- 600 Vac
- Secure end stops



Stackable

Build as you wish



MCBs and Accessories Data

1. Adjustable Current Ratings

From the FD range upwards, some breakers are fitted with adjustable magnetic trips. The suffix “V/E” types also have adjustable overload trips. “E” (electronic) types down to 50% of nominal rating and suffix “V” (mechanical) types down to 75% of nominal rating.

2. Calibration

CBI thermal breakers are calibrated at 40°C, unless otherwise stated. Derating for higher temperature environment to be done in accordance with derating curves.

3. Reverse Feeding

Contact CBI for details. Units indicated line / load should not be reverse fed.

4. Special Breakers

Prices for all breakers made by CBI to meet non-standard rating requirements of customer will be by quotation only.

5. Standard Current Ratings

Ampere ratings indicated are standard. Non-standard can be provided, on application at a surcharge of up to 20% of the next standard rating price, depending on quantity, product type and acceptance by CBI.

6. Switch Disconnecter Fault Ratings

The fault current ratings of CBI switch disconnectors which are fitted with shunt trips and external tripping devices are the same as those of the corresponding circuit breakers. Additional of interface barriers is mandatory.

7. Terminations

Consult CBI Catalogues for details.

8. Transient Inrush and Close Co-ordination Protection

Higher transient motor starting current associated with some high efficiency motors have created nuisance tripping problems. Consult CBI when in doubt.

9. DC Interrupting Capacity

Refer to CBI DC Catalogue for details.

10. Motor Starting

In addition to cable protection functions, the CBI circuit breakers are designed for induction motor starting and protection duties. These breakers are particularly suited to direct-on-line starting applications for standard type motors in conjunction with a contactor overload combination or as a stand-alone unit.

For complete details, refer to the “Motor Starting and Protection Application Guide” and “Circuit Breaker Selection Guide for DOL Motor Starting”.

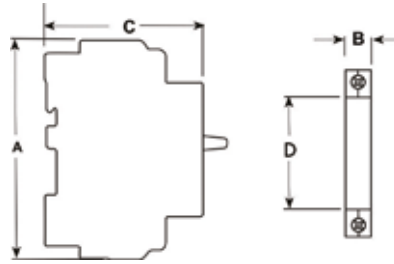

MCB Dimensions

MCB Dimensions				
Product	Height (A)	Width (B)	Depth (C)	Escutcheon (D)
QA - 1(13)	93	13	66	57
QA - 2(13)	93	26	66	57
QA - 3(13)	93	39	66	57
QF - 1(13)	93	13	66	57
QF - 2(13)	93	26	66	57
QF - 3(13)	93	39	66	57
QF - 4(13)	93	52	66	57
QF - 1(26)	93	26	66	57
QF - 2(26)	93	52	66	57
QF - 3(26)	93	78	66	57
QF - 4(26)	93	104	66	57
QF - 1(27)-D	97,5	27	65	45
QF - 2(27)-D	97,5	54	65	45
QF - 3(27)-D	97,5	81	65	45
QF - 4(27)-D	97,5	108	65	45
QF14 A/C - D	93	36	65	45
QA17 A/C	93	26	64,8	57
QF17 A/C	93	26	64,8	57
SM15A	122	65	66	57
SM36	122	117	66	57

Note: All measurements are in mm.

Technical Section

Technical Section: Motor Starting Guide 230 - 400 V

Motor Size (kW)	Single Phase Voltage 230 Vac		Three Phase Voltage 400 Vac			
	5 kA	5 kA	15 kA	25 kA	35 kA	65 kA
0.12	QF1 (5 A)*	QF3 (1 A)*	<p>Note: * External overload protection required. Curve 1 circuit breakers only ** Locked motor protection only</p>			
0.18	QF1 (5 A)*	QF3 (2 A)*				
0.25	QF1 (5 A)*	QF3 (2 A)*				
0.37	QF1 (10 A)*	QF3 (5 A)*				
0.55	QF1 (10 A)*	QF3 (5 A)*				
0.75	QF1 (10 A)*	QF3 (5 A)*				
1.1	QF1 (15 A)*	QF3 (5 A)*				
1.5	QF1 (15 A)*	QF3 (5 A)*				
1.8	QF1 (20 A)*	QF3 (10 A)*				
2.2	QF1 (20 A)*	QF3 (10 A)*				
3	QF1 (25 A)*	QF3 (10 A)*				
3.7	QF1 (30 A)*	QF3 (15 A)*				
4	QF1 (30 A)*	QF3 (15 A)*				
4.5	QF1 (35 A)*	QF3 (20 A)*				
5.2	QF1 (40 A)*	QF3 (20 A)*				
5.5	QF1 (45 A)*	QF3 (20 A)*				
6	QF1 (50 A)*	QF3 (20 A)*				
7	QF1 (60 A)*	QF3 (20 A)*				
7.5	QF1 (70 A)*	QF3 (25 A)*				
9.3	QF1 (80 A)*	QF3 (30 A)*				
11	QF1 (100 A)*	QF3 (35 A)*				
15		QF3 (45 A)*				
18.5		QF3 (60 A)*				
22		QF3 (70 A)*				
26		QF3 (80 A)*				
30		QF3 (100 A)*				
37		G15D (125 A)				
45		G15D (125 A)				
55		F15D (175 A)				
75		F15D (225 A)				
90		F15D 250 A / F25D (250 A)				
110		K25D (350 A)				
132		K25D (400 A)				
160		K35D (500 A)				
200		K35D (600 A)				
250		L35DE 800 (700 A)				
315		N85DE 1000 (900 A)				
355		N85DE 1000 (1000 A)				
400		N85DE 1250 (1200 A)				
450		N85DE 1250 (1250 A)				
500		N85DE 1600 (1400 A)				
560		N85DE 1600 (1600 A)				
630		ACB2000CM (1750 A)				
710		ACB2000CM (1900 A)				

Notes:

- All information in this table is for reference and selection purposes only, and only direct line (DOL) starting
 - Breaker selection is based on 4 Pole three phase squirrel cage motors and certain deviations may be encountered for different motor manufacturers
 - Circuit breaker settings are based on rated motor current multiplied by 1.6 to prevent starting current from exceeding the instantaneous pick-up current of the circuit breaker
 - For complete details refer to the "Circuit Breaker Selection Guide for DOL Motor Starting"
- ¹ These are adjustable breakers and the current in () is the Ampere value that these breakers must be set at
^{**} External overload protection required. Curve 1 circuit breakers only
^{**} Locked motor protection only

DOL: Contactor - Overload - MCCB Selection

Note: Customer to confirm motor FLC on site and adapt where necessary

Motor Rating 3PH kW	400 V HP	FLC AC3 A	Contactor Type MCM	Rating AC3 A	OL Relay Type OR	Setting Range A	MCCB	Rating A	Cable Size mm ²
5.5	7.5	11.3	ST20	18	THT18-11	9 to 13 A	G15D	20	2.5
7.5	10	15.2	ST20	18	THT18-15	12 to 18 A	G15D	40	2.5
11	15	21.7	ST35	40	THT25-22	18 to 26 A	G15D	40	4
15	20	29.3	ST35	40	THT50-29	24 to 34 A	G15D	50	10
18.5	25	36	ST35	40	THT50-29	24 to 34 A	G15D	63	10
22	30	41	ST50	50	THT50-42	34 to 50 A	G15D	100	10
30	40	55	ST65	65	THT65-54	43 to 65 A	G15D	100	16
37	50	68	ST80	85	THT100-67	54 to 80 A	G25D	125	25
45	60	81	ST80	85	THT100-82	65 to 100 A	G25D	125	35
55	75	99	ST100	100	THT100-95	85 to 105 A	G25D	175	35
75	100	134	SN150	150	THN120-125	100 to 150 A	F25D	225	50
90	125	161	SN180	185	THN220-150	120 to 180 A	F25D	250	95
110	150	196	SN220	225	THN220-210	170 to 250 A	K25D	350	95
132	180	231	SN300	225	THN400-250	200 to 300 A	K25D	400	150
160	220	279	SN300	330	THN400-330	260 to 400 A	K35D	500	185
200	270	349	SN400	400	THN400-330	260 to 400 A	K35D	600	240

Motor Rating 3PH kW	500 V HP	FLC AC3 A	Contactor Type MCM	Rating AC3 A	OL Relay Type OR	Setting Range A	MCCB	Rating A	Cable Size mm ²
5.5	7.5	9	ST20	13	THT18-9	7 to 11 A	G15D	16	1.5
7.5	10	12.1	ST20	13	THT18-11	9 to 13 A	G15D	20	2.5
11	15	17.4	ST35	32	THT25-22	18 to 26 A	G15D	40	2.5
15	20	23.4	ST35	32	THT25-22	18 to 26 A	G15D	40	6
18.5	25	28.9	ST35	32	THT50-29	24 to 34 A	G15D	50	6
22	30	33	ST50	43	THT50-29	24 to 34 A	G15D	50	10
30	40	44	ST65	60	THT65-42	34 to 50 A	G15D	100	10
37	50	54	ST80	75	THT65-54	43 to 65 A	G15D	100	16
45	60	65	ST80	75	THT100-67	54 to 80 A	G15D	125	25
55	75	79	ST100	85	THT100-82	65 to 100 A	G15D	125	35
75	100	107	SN150	100	THN120-125	100 to 150 A	F35D	175	50
90	125	129	SN180	185	THN220-150	120 to 180 A	F35D	200	50
110	150	157	SN180	180	THN220-150	120 to 180 A	K35D	250	95
132	180	184	SN220	200	THN220-210	140 to 250 A	K35D	300	95
160	220	224	SN300	280	THN400-250	200 to 300 A	K35D	350	150
200	270	279	SN400	350	THN400-330	260 to 400 A	K35D	400	185

Star Delta Starting: Contactor - Overload - MCCB Selection

Note: Customer to confirm motor FLC on site and adapt where necessary

Motor Rating 3PH kW	400 V HP	FLC AC3 A	Main Contactor Type MCM	Rating AC3 A	Delta Contactor Type MCD	Star Contactor Type MCY	TOR OL Relay Type CMT	Setting Range A	MCCB	Rating A	Cable Size mm ²
5.5	7.5	11.3	ST20	18	ST20	ST20	THT18-11	9 to 13 A	G15D	20	2.5
7.5	10	15.2	ST20	18	ST20	ST20	THT18-15	12 to 18 A	G15D	40	2.5
11	15	21.7	ST35	18	ST35	ST20	THT25-22	18 to 26 A	G15D	40	4
15	20	29.3	ST35	22	ST35	ST20	THT50-35	30 to 40 A	G15D	63	10
18.5	25	36	ST35	22	ST35	ST20	THT50-42	34 to 50 A	G15D	80	10
22	30	41	ST50	40	ST50	ST35	THT50-42	34 to 50 A	G15D	100	10
30	40	55	ST65	40	ST65	ST35	THT65-54	43 to 65 A	G15D	125	16
37	50	68	ST80	50	ST80	ST50	THT100-67	54 to 80 A	F15D	150	25
45	60	81	ST80	65	ST80	ST50	THT100-82	65 to 100 A	F15D	175	35
55	75	99	ST100	65	ST100	ST50	THN120-105	85 to 125 A	F15D	200	35
75	100	134	SN150	85	SN150	ST80	THN120-125	100 to 150 A	K25D	300	50
90	125	161	SN180	105	SN180	ST100	THN220-150	120 to 180 A	K25D	350	95
110	150	196	SN220	130	SN220	SN150	THN220-210	170 to 250 A	K25D	400	95
132	180	231	SN300	150	SN300	SN150	THN400-250	200 to 300 A	K35D	500	150
160	220	279	SN300	185	SN300	SN150	THN400-330	260 to 400 A	K35D	630	185

Motor Rating 3PH kW	500 V HP	FLC AC3 A	Contactor Type MCM	Rating AC3 A	Delta Contactor Type MCD	Star Contactor Type MCY	OL Relay Type OR	Setting Range A	MCCB	Rating A	Cable Size mm ²
5.5	7.5	9	ST20	17	ST20	ST20	THT18-11	9 to 13 A	G15D	20	1.5
7.5	10	12.1	ST20	17	ST20	ST20	THT18-15	12 to 18 A	G15D	32	2.5
11	15	17.4	ST25	24	ST25	ST20	THT25-22	18 to 25 A	G15D	40	2.5
15	20	23.4	ST25	24	ST25	ST20	THT25-22	18 to 26 A	G15D	40	6
18.5	25	28.9	ST35	32	ST35	ST20	THT50-35	30 to 40 A	G15D	63	6
22	30	33	ST35	32	ST35	ST20	THT50-35	30 to 40 A	G15D	63	10
30	40	44	ST65	60	ST65	ST35	THT50-42	34 to 50 A	G15D	80	10
37	50	54	ST65	60	ST65	ST35	THT65-54	43 to 65 A	G15D	125	16
45	60	65	ST80	75	ST80	ST50	THT100-67	54 to 80 A	F15D	150	25
55	75	79	ST100	85	ST100	ST50	THT100-82	65 to 100 A	F15D	175	35
75	100	107	SN150	140	SN150	ST100	THN120-105	85 to 125 A	F15D	200	50
90	125	129	SN150	140	SN150	ST100	THN220-150	120 to 180 A	K25D	300	50
110	150	157	SN180	180	SN180	ST100	THN220-150	120 to 180 A	K25D	350	95
132	180	184	SN220	200	SN220	SN125	THN220-210	170 to 250 A	K25D	400	95
160	220	224	SN300	250	SN300	SN150	THN400-250	200 to 300 A	K35D	500	150

DOL Starting (Full Load)

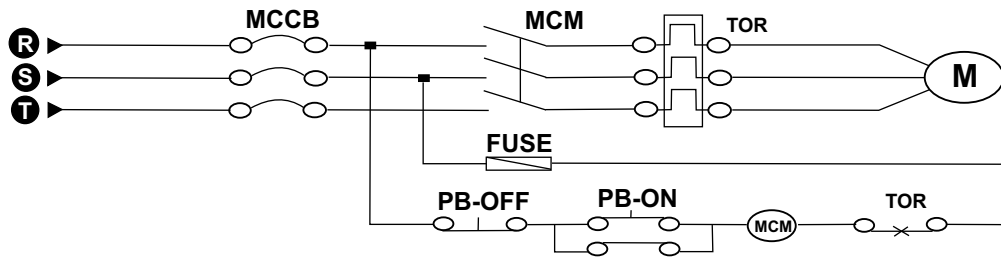

Conditions

1. The load shall be an Induction Motor with 3 phase and 4 poles
2. The overload relay setting range is selected according to the full load current of the motor
3. The cross-section area of the cable is within the value that is connectable to the motor starter
4. The circuit breaker (MCCB) is for cable protection

The breaking capacity of the MCCB should be reviewed according to the site conditions.

Star Delta Starting Y: Δ

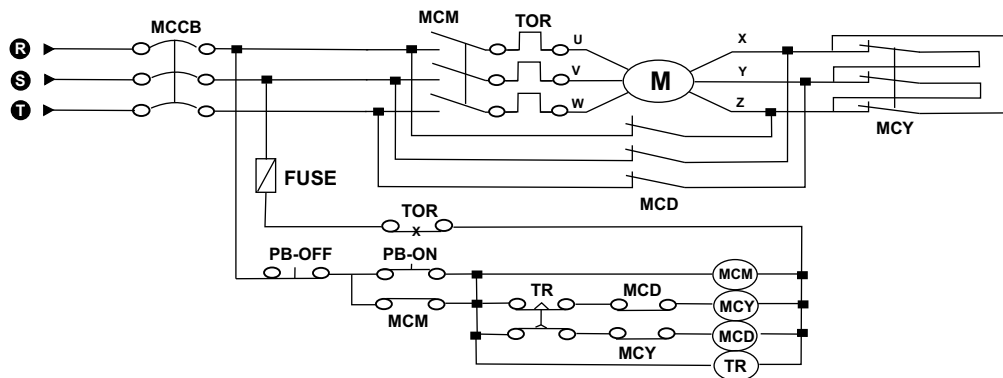

Conditions

1. The load shall be a squirrel cage motor with 3 phase and 4 poles
2. The overload relay setting range is selected according to the full load current of the motor
3. When the Thermal Overload Relay (TOR) is placed in the area shown the setting range should be divided by $\sqrt{3}$ (0.58)
4. The cross-section area of the cable is within the value that is connectable to the motor starter.
5. Thermal Overload Relay (TOR) mounting:*
 - Separately mountable with an optional mounting unit
 - Directly mountable when placed in the area shown in the dotted line

The breaking capacity of the MCCB should be reviewed according to the site conditions.

Note:

* Contact CBI for availability

Terminations







JSO / J25S		K25D / K35D	
G1	Ratings 15 - 150 A 	G4B	Supplied as Standard (No spares)  x 3 of each
L20B / L40B		J25S / FD	
G4B	 x 3 of each 4120166	G4B	Ratings 15 - 250 A  x 1 of each x 2 of each FSAX001

Notes:

Refer to product specific pages for actual terminal types - may not be available as separate items if supplied as standard. For relevant current carrying capacities, please refer to relevant products.

MCCB Terminal Bolt Sizes	
Frame Size	Bolt Size
JS / JSN	M8
LB / LBN	M12
MB / MBN	M12
GD / GDN / ELGD	M8
FD / FDN / ELFD	M8
KD / KDN / ELKD	M12
LD / LDN	M12
NDE / NDN (1000 A & 1250 A)	M12
NDE (1600 A)	M10

Torque Settings MCCB

Terminal Screw	Screw Diameter	M5	M6	M8		M10	M12
	Shape						
	Fastening Torque Nm	2 - 3	2.5 - 4.5	5.0 - 7.0	8.0 - 13.0	20.0 - 30.0	40.0 - 50.0

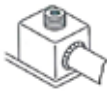
Solderless Terminal Screw	Screw Diameter	M5	M10	M16	M18	M20	M24
	Shape						
	Fastening Torque Nm	4.0 - 6.0	3.5 - 4.5	20.0 - 30.0	30.0 - 40.0	30.0 - 40.0	50.0 - 60.0

**This is a series connected (cascading) system
Replacement of the circuit breakers other than those of identical types
and ratings should be referred to the circuit breaker manufacturer**

Cascading Tables

Note:

Any current limiting by the cables should be taken into account

The cascading table is applied in practice as follows:

1. Determine the maximum prospective short circuit fault current level at the point of installation of the upstream breaker in the cascade
2. Moving from the left side towards the right side of the cascading table, in the **top** row, select an upstream breaker whose breaking capacity is equal to or greater than determined by (1.) above
3. Determine the prospective short circuit current at the installation point of the **downstream** breaker, taking into account only the current limiting effect of any cable that is connected between the upstream and downstream breakers. Any current limiting by the upstream breaker should be ignored for this purpose.
4. From the first column on the left of the cascading table, select the **row** that represents a short circuit current that is equal to or higher than this latter short circuit current
5. The **downstream** breaker suitable for the cascading application will then be found at the intersection of the row from (2.) above, and the column from (4.) above

Due to constant research and development, CBi reserves the right to make changes, modifications and extensions to these cascading tables without prior notice.

No substitute of any alternative product is allowed

Care must be taken in replacing older product versions or obsolete ranges



Cascading Table (CBI MCBs and MCCBs)

Upstream Circuit Breakers

No of Poles	G15D / F15D		G25D / F25D		G35D / F35D		F65DV		K25D	K35D K50DE K35DE	K70DE K65DE	L70DE L50DE L35DE	Busbar Rating kArms
	15	250	25	250	35	250	100	250	25	35	65	65	
Fault Level kA	15	250	25	250	35	250	100	250	400	400 / 630	400 / 630	800	
Amp Rating	125	250	125	250	125	250	100	250	400	400 / 630	400 / 630	800	
Protective Downstream Fault Level kArms	65						F15D	F15D					20
	50						F15D	F15D					20
	35					QF1	F15D QF1	F15D QF1					15
	30					QF1	F15D QF	QF1 QF		G15D F15D	G15D F15D	G15D F15D	15
	25			QF1	F15D QF	QF1	QF1 QF	QF	G15D F15D	G15D F15D	G15D F15D	G15D F15D	15
	20			QF	QF1 QF	QF	QF1 QF	QF	G15D F15D	G15D F15D	QF1	G15D F15D	15
15	QF	QF1 QF	QF	QF1 QF	QF	QF1 QF	QF	QF1	QF1	QF1	QF1	QF1	10
	10	QF	QF	QF	QF	QF	QF	QF	QF	QF1	QF1	QF1	10

Notes:

QF = QF(13), QF(18), QF(26)

QF1 = Single pole circuit breakers

QF = Single, double or triple pole circuit breakers

Type	Mounting Type	Escutcheon, mm
QF	Mini / DIN	57
	DIN	45

Review: June 2020

For more product information regarding cascading, please contact CBI

Cascading Table No. 2

Cascading Table (CBI MCBs and MCCBs) - Hydraulic-Magnetic

Upstream Circuit Breakers @ 415 V

	JS25	J25S	J25SN **	L20B	L20BN **	L40B	L40BN **	M25B	M35B	M35BN **	Busbar Rating kArms
No of Poles	1	3	3	3	3	3		3	3	3	
Fault Level KA	25	25	25	20	20	40	40	25	35	35	
Amp Rating	80 - 250	50 - 250	100 - 250	100 - 600	300 - 600	100 - 600	300 - 600	700 / 830	700 / 830	830	
Protective Level Arms Downstream Fault	65										20
	50										
	35					QF	QF		QF	QF	15
	30					QF	QF		QF	QF	
	25	QF	QF	QF	QF	QF	QF	QF	QF	QF	
20	QF	QF	QF	QF	QF	QF	QF	QF	QF		
15	QF	QF	QF	QF	QF	QF	QF	QF	QF		
10	QF	QF	QF	QF	QF	QF	QF	QF	QF	QF	

Notes:

** Withstand current must be backed up by suitable Short Circuit Protection Device. ** SABS / IEC 60947-3

QF: Single Pole, Double Pole, Triple Pole - Slow Curve 1 & Medium Curve 2 circuit breakers - Hydraulic Magnetic type

QF: QF(26) per pole

No substitute of any alternative product is allowed
Care must be taken in replacing older product versions or obsolete ranges

Type	Mounting Type	Escutcheon, mm
QF	Mini / DIN	57
	DIN	45

Review: August 2024

For more product information regarding cascading, please contact CBI

Mitsubishi DOL Starting

Mitsubishi DOL		
Motor Size (kW)	Three phase voltage - 400 Vac	Three phase voltage - 525 Vac
0.37	NF63-HVA 10 A, NV63-HVA 16 A, NV125-SVA/HVA 16 A	NF63-HVA 10 A, NV63-HVA 16 A, NV125-SVA/HVA 16 A
0.55	NF63-HVA 10 A, NV63-HVA 16 A, NV125-SVA/HVA 16 A	NF63-HVA 10 A, NV63-HVA 16 A, NV125-SVA/HVA 16 A
0.75	NF63-HVA 10 A, NV63-HVA 16 A, NV125-SVA/HVA 16 A	NF63-HVA 10 A, NV63-HVA 16 A, NV125-SVA/HVA 16 A
1.1	NF63-HVA 10 A, NV63-HVA 16 A, NV125-SVA/HVA 16 A	NF63-HVA 10 A, NV63-HVA 16 A, NV125-SVA/HVA 16 A
1.5	NF63-HVA 10 A, NV63-HVA 16 A, NV125-SVA/HVA 16 A	NF63-HVA 10 A, NV63-HVA 16 A, NV125-SVA/HVA 16 A
2.2	NF63-HVA 10 A, NV63-HVA 16 A, NV125-SVA/HVA 16 A	NF63-HVA 10 A, NV63-HVA 16 A, NV125-SVA/HVA 16 A
3	NF63-HVA 10 A, NV63-HVA 16 A, NV125-SVA/HVA 16 A	NF63-HVA 10 A, NV63-HVA 16 A, NV125-SVA/HVA 16 A
4	NF63-HVA 16 A, NF125-SVA/HVA 16 A, NV125-SVA/HVA 16 A	NF63-HVA 10 A, NV63-HVA 16 A, NV125-SVA/HVA 16 A
5.5	NF63-HVA 20 A, NF125-SVA/HVA 20 A, NV125-SVA/HVA 20 A	NF63-HVA 16 A, NF125-HVA 16 A, NV125-SVA/HVA 16 A
7.5	NF63-HVA 32 A, NF125-SVA/HVA 32 A, NV125-SVA/HVA 32 A	NF63-HVA20 A, NF125-HVA 20 A, NV125-SVA/HVA 20 A
11	NF63-HVA 40 A, NF125-SVA/HVA 40 A, NV125-SVA/HVA 40 A	NF63-HVA32 A, NF125-HVA 32 A, NV125-SVA/HVA 32 A
15	NF63-HVA 50 A, NF125-SVA/HVA 50 A, NV125-SVA/HVA 50 A	NF63-HVA40 A, NF125-HVA 40 A, NV125-SVA/HVA 40 A
18.5	NF63-HVA 63 A, NF125-SVA/HVA 63 A, NV125-SVA/HVA 63 A	NF63-HVA50 A, NF125-HVA 50 A, NV125-SVA/HVA 50 A
22	NF125-SVA/HVA 80 A, NV125-SVA/HVA 80 A	NF63-HVA50 A, NF125-HVA 50 A, NV125-SVA/HVA 50 A
30	NF125-SVA/HVA 100 A, NV125-SVA/HVA 100 A	NF125-SVA/HVA 80 A, NV125-SVA/HVA 80 A
37	NF250-SVA/HVA 125 A, NV125-SVA/HVA 125 A	NF125-SVA/HVA 80 A, NV125-SVA/HVA 80 A
45	NF250-SVA/HVA 125 A, NV125-SVA/HVA 125 A	NF125-SVA/HVA 100 A, NV125-SVA/HVA 100 A
55	NF250-SVA/HVA 175 A, NV250-SVA/HVA 175 A	NF250-SVA/HVA 125 A, NV250-SVA/HVA 125 A
75	NF250-SVA/HVA 225 A, NV250-SVA/HVA 225 A	NF250-SVA/HVA 175 A, NV250-SVA/HVA 175 A
90	NF250-SVA/HVA 250 A, NF400-SW 250 A, NV400-SW 250 A	NF250-SVA/HVA 200 A, NV250-SVA/HVA 200 A
110	NF400-CW/SW 350 A, NV400-SW 350 A	NF250-SVA/HVA 250 A, NF400-CW/SW 250 A, NV400-SW 250 A
132	NF400-CW/SW 400 A, NV400-SW 400 A	NF400-CW/SW 300 A, NV400-SW 300 A
160	NF630-CW/SW 500 A, NV630-SW 500 A	NF400-SW 350 A, NV400-SW 350 A
200	NF630-CW/SW 600 A, NV630-SW 600 A	NF630-CW/SW 500 A, NV630-SW 500 A
250	NF800-CEW/SEW (700 A)*, NV800-SEW (700 A)*	NF630-CW/SW 600 A, NV630-SW 600 A
315	NF1000-SEW (900 A)*, AE1000-SW (900 A)*	NF800-CEW/SEW (700 A)*, NV800-SEW (700 A)*
355	NF1000-SEW (1000 A)*, AE1000-SW (1000 A)*	NF800-CEW/SEW (800 A)*, NV800-SEW (800 A)*
400	NF1250-SEW (1200 A)*, AE1250-SW (1200 A)*	NF1000-SEW (900 A)*, AE1000-SW (900 A)*
450	NF1250-SEW (1250 A)*, AE1250-SW (1250 A)*	NF1000-SEW (1000 A)*, AE1000-SW (1000 A)*
500	NF1600-SEW (1400 A)*, AE1600-SW (1400 A)*	NF1250-SEW (1200 A)*, AE1250-SW (1100 A)*
560	NF1600-SEW (1600 A)*, AE1600-SW (1600 A)*	NF1250-SEW (1200 A)*, AE1250-SW (1200 A)*
630	AE2000-SW/SWA (1750 A)*	NF1600-SEW (1400 A)*, AE1600-SW (1300 A)*
710	AE2000-SW/SWA (1900 A)*	NF1600-SEW (1500 A)*, AE1600-SW (1500 A)*

AGREED GENERAL TERMS & CONDITIONS OF SALES

This document is an abridged version of the general terms and conditions of sale of Circuit Breaker Industries (Pty) Ltd (“CBI”) and serves only as a summary of the main provision of CBI’s general terms and conditions of sale. The latter shall prevail in all circumstances should there be any conflict between them and this abridged version of the general terms and conditions of sale. A copy of the general terms and conditions of sale is available upon request.

1. APPLICABILITY, PRECEDENCE

- 1.1 This Agreement (as defined below):
- 1.1.1 shall govern all transactions for the sale of Goods (as defined below), by:
- 1.1.1.1 Circuit Breaker Industries (Pty) Ltd t/a CBI-electric: low voltage (registration number 1943/15747/07) of 1 Tripswitch Drive, Elandsfontein, Johannesburg, South Africa (hereinafter the “Seller”, as further defined below), to
- 1.1.1.2 the legal/natural person/s identified and described on the Buyer Application Form (the “BAF”) hereto (hereinafter the “Buyer”, as further defined below);
- 1.1.2 will only be amended or varied or cancelled or replaced or waived to the extent expressly agreed to in writing and signed by the authorised representatives of each Party;
- 1.1.3 shall supersede, overrule and prevail over any terms and conditions of contract of the Buyer, either as submitted in documentary form to the Seller or found elsewhere, including on any website, unless specifically otherwise agreed between the Parties in writing.
- 1.1.4 If there are any discrepancies or conflict between the provisions of the terms and conditions contained in clauses 1 to 21 hereof, and:
- 1.1.4.1 any annexure/s hereto (clause 23 and further), the provisions of the annexure/s shall prevail;
- 1.1.4.2 the completed BAF, these terms and conditions shall prevail;
- 1.1.4.3 any accepted Purchase Order (as defined below), the provisions of the accepted Purchase Order shall prevail in respect of that specific Purchase Order only.

2. INTERPRETATION, DEFINITIONS

- 2.1 In this Agreement:
- 2.1.1 clause headings are for reference purposes only and shall not influence the interpretation;
- 2.1.2 reference to:
- 2.1.2.1 one gender shall include the other genders;
- 2.1.2.2 natural persons include juristic persons and vice versa;
- 2.1.2.3 the singular shall include the plural and vice versa;
- 2.1.2.4 days, months or years shall be construed as Gregorian calendar days, months or years;
- 2.1.3 if any provision in a definition is a substantive provision conferring rights or imposing obligations on a Party (as defined below), effect shall be given to it as if it were a substantive provision in the body of the Agreement;
- 2.1.4 where figures are referred to in numerals and in words, if there is any conflict, the words shall prevail;
- 2.1.5 all annexures hereto shall be deemed to be incorporated herein and shall form an integral part hereof;
- 2.1.6 expressions defined in this Agreement shall bear the same meanings in annexures hereto;
- 2.1.7 durations shall be reckoned exclusively of the first and inclusively of the last day.
- 2.2 The following capitalised terms shall have the meanings assigned to them hereunder and cognate expressions shall have corresponding meanings:
- 2.2.1 “Agreement” means:
- (i) the completed BAF,
- (ii) these terms and conditions (clauses 1 to 21),
- (iii) any annexure hereto (clause/s 23 and further),
- (iv) any Purchase Order accepted hereunder,
- as the same may be amended, modified or supplemented from time to time in accordance with the terms of this Agreement.
- 2.2.2 “BAF” means the buyer application form, (forming part of this Agreement), which shall be fully completed by the Buyer before Signature Date, by including the requested information thereon.
- 2.2.3 “Business Day” means any day except a Saturday, Sunday or statutory public holiday in South Africa.
- 2.2.4 “Buyer” means the Party identified and more fully described as the Buyer in the BAF, to whom the Seller sells the Goods under this Agreement.
- 2.2.5 “Commercial Use” means use by the Buyer of the Goods in the ordinary course of business, or substantial readiness for such use.
- 2.2.6 “Corrupt Act” means any offence in respect of corruption or corrupt activities contemplated in the Prevention and Combatting of Corrupt Activities Act, 12 of 2004.
- 2.2.7 “CPA” means the Consumer Protection Act, 68 of 2008.
- 2.2.8 “Delivery” means, regardless whether the word is capitalised or not, delivery of Goods in accordance with the applicable Incoterms.
- 2.2.9 “Effective Date” means, irrespective of Signature Date, the date on which the Purchase Order is accepted by the Seller and any suspensive conditions agreed to by the Parties have been fulfilled.
- 2.2.10 “Goods” means the circuit breakers, equipment, parts, components, and materials sold by the Seller to the Buyer under this Agreement, as set out in a PO.
- 2.2.11 “Incoterms” means the International Commercial Terms 2010 rules, published by the International Chamber of Commerce.
- 2.2.12 “Intellectual Property” means all intellectual property rights, whether registered or unregistered in any jurisdiction, including but not limited to know-how, designs, copyright, registered trademarks and applications therefor, registered designs and applications therefor, patents and applications therefor.
- 2.2.13 “Parties” means the Buyer and the Seller collectively, and “Party” means either of them.
- 2.2.14 “POPI” means the Protection of Personal Information Act, 4 of 2013.
- 2.2.15 “Proof of Delivery”, “POD” means written acknowledgement by the Buyer that the Goods have been duly delivered, as provided in clause 6.
- 2.2.16 “Purchase Order/PO” means an official, written order issued by the Buyer to the Seller to supply Goods.
- 2.2.17 “Seller” means Circuit Breaker Industries (Pty) Ltd, t/a CBI-electric: low voltage, the Party selling the Goods to the Buyer under this Agreement.
- 2.2.18 “Signature Date” means the date last in time on which either Party signs this Agreement, as indicated in clause 21.
- 2.2.19 “South Africa” means the Republic of South Africa.
- 2.2.20 “Warranty Period” means the specific period of time for which the warranty is granted for a specific type and range of Goods, as stated in clause 23 (Annexure “A” hereto), and as described more fully in clause 10.2 hereof.

3. PRICES

- 3.1 All prices are quoted in the currency agreed to, and if it is South African Rand (ZAR), it shall exclude Value Added Tax which will be separately quoted.
- 3.2 Prices are stated and delivery will be according to the Incoterm agreed upon in the BAF. If no other specific Incoterm is agreed therein, then by default the applicable Incoterm shall be Ex- Works, the Seller’s factory, Elandsfontein, Gauteng (EXW).
- 3.3 If specific prices are not quoted in writing for a PO, the price of any Goods shall be the price stated in the Seller’s standard price list in force at the date of quotation of the Goods.
- 3.4 The price of Goods sold to the Buyer is strictly net and not subject to any discounts unless otherwise agreed upon in writing. If any discount is so agreed, it shall only be allowed if payment is received by the Seller strictly by the due date and shall only apply to the actual price of the Goods themselves and not to any transport costs, insurance, storage charges or other duties or taxes.
- 3.5 The sale of the Goods reflected on the invoice in question does not include installation costs unless otherwise so agreed in writing.

4. PAYMENT TERMS

- 4.1 The prices for the Goods and all other amounts due under this Agreement shall be due and payable within the period of the credit terms, agreed to between the Parties in writing, calculated from date of the Seller’s monthly statement.
- 4.2 If not otherwise agreed in writing, payment shall be made by electronic funds transfer into the Seller’s nominated bank account in clause 6 and the Buyer shall immediately e-mail proof of payment to the Seller. The Buyer shall be deemed to have paid the amount stated on the proof of payment only after the Seller has actually received the payment.
- 4.3 In the event that the Seller shall agree (in writing) to permit that payment be made by way of a letter of credit, such letter of credit shall be drawn on a bank acceptable to the Seller and on terms and conditions as may be acceptable to it, in its sole discretion.
- 4.4 Any late payment of amounts that are due and payable by the Buyer to the Seller under this Agreement may attract interest at rate of prime interest rate quoted by Nedbank Limited from time to time per annum plus the amount of percentage points agreed in the BAF, compounded monthly in arrears.
- 4.5 All payments received by the Seller, shall be appropriated firstly in respect of interest and thereafter in respect of capital amounts payable, it being recorded and agreed that the Seller shall be entitled to appropriate payments received from the Buyer to whichever of the Buyer’s debts as the Seller may in its sole discretion elect.
- 4.6 A certificate issued and signed by a director or duly authorised manager of the Seller, whose authority need not be proved, stating the amount owing and/or the amount of interest payable by the Buyer, is prima facie proof of the facts stated therein and the amount of the indebtedness of the Buyer to the Seller. The certificate may be used in support of any application by the Seller for default- or summary judgment, provisional sentence, or any other legal or arbitration proceedings.
- 4.7 The Buyer shall not be entitled to withhold payment of the prices or any other amount legally due for any reason whatsoever, notwithstanding that a dispute may be pending between the Parties or as a retention or as a result of a third party not paying the Buyer for any Goods sold to them, nor shall the Buyer be entitled to make any deduction from the prices or any other amount due, or to set off any alleged claim against the amounts due by the Buyer to the Seller.
- 4.8 The Buyer may not cancel any Purchase Order placed, except upon written notice and only if accepted by the Seller (in writing) on payment of a reasonable cancellation charge determined by the Seller.
- 4.9 The Buyer hereby acknowledges and agrees that information regarding its payment behaviour may be disclosed to any registered credit bureau and/or any other suppliers.

5. BANK ACCOUNT DETAILS

- 5.1 The Seller’s bank account details are attached hereto, as Annexure “B” (clause 24).
- 5.2 This banking account details will not be amended by the Seller by way of email or telephone, but will only be amended by written notification by the appointed representative of the Seller.
- 5.3 The Buyer indemnifies and shall hold the Seller harmless against any claim, damage, cost, liability and expense including reasonable attorney’s fees caused by, relating to or arising from the Buyer making payment into any other account than the above mentioned account.

6. DELIVERY

- 6.1 Goods delivered in terms of the Seller’s local ordering policy within South Africa, shall be delivered by the Seller according to the agreed Incoterm (BAF) or failing which, at the Seller’s cost and discretion, either by post to the Buyer at the Buyer’s place of business, or delivered by road or rail to the Buyer’s place of business.
- 6.2 If Goods are mailed, delivery will take place upon posting, even if the use of post was not authorised by the Buyer.
- 6.3 If any permit, licence or authorisation is required for
- 6.3.1 the export of Goods from South Africa and/or import into the Buyer’s country;
- 6.3.2 the transport of Goods, or
- 6.3.3 payment to be effected in accordance with this Agreement, then, subject to the applicable Incoterms agreed to herein, the Buyer shall obtain such permit, licence or authorisation timeously and at its own cost.
- 6.4 Should the Seller at the Buyer’s request, which request may be granted or refused at the Seller’s sole discretion, agree to engage a third party (“Shipping Agent”) to supply courier or transport services in regards to the Goods on behalf of the Buyer, then the Seller is hereby:
- 6.4.1 authorised to engage a Shipping Agent as agent for the Buyer on such terms and conditions as it deems fit; and
- 6.4.2 indemnified by the Buyer against all demands and claims which may be made against it by the Shipping Agent so engaged and all liability which the Seller may incur to the Shipping Agent or any third party arising out of the transportation of the Goods.
- 6.5 The Buyer shall immediately upon receipt thereof check the content of the Goods. On signature of the Proof of Delivery by any employee or agent of the Buyer, the Buyer is deemed to have received the Goods referred to in the Purchase Order or any other delivery notice, without shortage or visual defect and the Buyer shall have no claim against the Seller for non-delivery of, or shortages or visual defects in the Goods. Should the Buyer fail to sign the Proof of Delivery prior to the Shipping Agent’s or Buyer’s vehicle leaving the point of delivery, the signature of a representative of the Seller shall be prima facie proof that the Goods were delivered without visual defect or shortage.

AGREED GENERAL TERMS & CONDITIONS OF SALES

6.6 Time is not of the essence for Delivery of the Goods, and the Seller shall not be liable for any loss or damage of any nature whatsoever, should delivery of Goods not be made within the period stated in the Purchase Order or the Seller's documentation.

6.7 Should delivery of any Goods not be accepted by the Buyer, consignee or party nominated by the Buyer to accept delivery, then the Seller shall, in its sole discretion:

6.7.1 be entitled to return and store the Goods and any part thereof at no risk to the Seller and at the expense of the Buyer; or

6.7.2 sell the Goods in execution and retain the proceeds thereof as rouwkoop or as liquidated damages for the settlement or part settlement of the return and storage of the Goods.

7 STANDARDS AND TESTING

7.1 The Goods shall comply to those standards indicated on the particulars Goods, as well as applicable legislation and safety standards that are prescribed for the particular Goods.

7.2 No provision has been made in the prices of the Goods for the performance of any special or additional tests and, subject to clause 7.4 below, the Seller shall not be liable for the performance of such special or additional tests.

7.3 If any acceptance tests are agreed by the Parties, Commercial Use constitutes final acceptance regardless whether the tests have been carried out or not.

7.4 If the Buyer requests the Seller to do special or additional tests over and above the standard prescribed tests, the Seller may in its sole discretion do so, subject to the Parties agreeing to a price for such testing.

8 RISK, OWNERSHIP AND INSURANCE

8.1 The risk passes to the Buyer in terms of the stated and agreed Incoterm (BAF).

8.2 Notwithstanding the date of Delivery and notwithstanding the date of passing of the risk, ownership in the Goods only passes to the Buyer on receipt by the Seller of the full price in respect of the Goods.

8.3 The Buyer shall at all times fully and adequately insure those Goods supplied to it, but wherein ownership has not yet passed to it, against all forms of loss.

8.4 Pending payment to the Seller for Goods purchased, all benefits in terms of the insurance policy relating to the insurance of such Goods, are hereby ceded to the Seller.

9 APPOINTED REPRESENTATIVES

9.1 In the BAF, the Seller and the Buyer each appoints a representative to liaise with the other regarding day-to-day decisions in connection with the performance of this Agreement. The appointed representatives shall each have the power to make all such decisions as may be required from him by the other Party (except to vary the Agreement or any price or amount due hereunder) and the other Party shall be entitled to act upon such decisions.

9.2 The Parties shall not accept instructions or requests from the other Party other than through the appointed representative, and all such instructions and/or requests shall be in writing.

9.3 The appointed representative of a Party may be changed by written notice.

10 WARRANTY AND RETURN OF GOODS

10.1 The Seller shall not be liable on the ground of any common law warranty in respect of the Goods, including without limitation against latent defects in, or relating to "fitness for purpose" of, the Goods.

10.2 Subject to clause 10.1, the Seller warrants that the type of Goods listed in clause 23.1 (Annexure "A") hereto, will be free from defects in material and workmanship under normal use and service for the particular Warranty Period, agreed to in that clause. The Warranty Period shall never be longer than the specific period prescribed for the particular type of Goods. The Warranty Period commences on the date of manufacturing of the Goods.

10.3 The Seller shall make good any defect, by repair or at its option replacement, which appears in the Goods during the applicable Warranty Period, provided that:

10.3.1 the Seller is notified in writing within 5 (five) Business Days of the alleged defect occurring, and

10.3.2 the Buyer has fulfilled all its obligations under this Agreement.

10.4 The provisions of clause 10.3 shall however not apply where the defect in the Goods arose, in the Seller's reasonable opinion:

10.4.1 due to the modification of or incorrect application of the Goods, the unauthorised tampering, or the changing or adjustments in, or any other unauthorised modifications of the Goods in question (including seals, date stamps or coding); or

10.4.2 as a result of force majeure (as defined below), lightning, water, electromagnetic disturbances, dust or other environmental conditions, unless the Seller has warranted to the Buyer that the Goods in question were specifically designed to cater for such conditions or contingencies.

10.5 Without derogating from the provisions of clauses 10.1 to 10.4 above, and in the event that the Seller shall in writing agree to replace or repair or examine any Goods in order to determine whether it is prepared to replace or repair such Goods:

10.5.1 the Buyer shall be liable to pay for the cost of delivering the Goods in question to the Seller;

10.5.2 the Seller shall be entitled to levy, in which event the Buyer shall pay in advance, a handling fee up to a maximum of 10 % (ten percent) of the purchase price of such Goods, which handling fee may also be payable in those circumstances where the Seller shall refuse to repair or replace such Goods; and

10.5.3 the Seller shall not be liable to the Buyer for any loss or damage of whatsoever nature suffered by it in the event that any Goods are lost or damaged while in the Seller's possession and under its control, under the above circumstances.

10.6 Further without derogating from the provisions of the previous clauses (10.1 to 10.5), the Seller may in its sole discretion determine whether correctly supplied and invoiced Goods, and which have no defects or are not subject to any claim, will be returned, and whether handling charges will be levied therefore.

10.7 Further to the provisions of clause 10.6 above, and if in the exercise of its discretion, the Seller, at the request of the Buyer agrees, to accept the return of any such Goods for credit, then the Seller shall be entitled, without the necessity of any further agreement, to claim from the Buyer a handling fee up to a maximum of 10 % (ten percent) of the invoice price of the Goods so returned.

11 CPA

11.1 The Buyer warrants and represents that, to the extent that its activities are subject to the CPA, it shall ensure compliance with all provisions of the CPA in its dealings with end-users of the Goods or consumers, irrespective of the provisions of this Agreement.

11.2 The Buyer acknowledges that if, at Signature Date, it is a juristic person (as defined in the CPA), and its annual turnover or asset value, as indicated in the BAF:

11.2.1 exceeds the threshold determination stated in section 5 the CPA, the transaction/s contemplated in terms of this Agreement is exempt from the majority of the provisions of the CPA, alternatively

11.2.2 does not exceed the stated threshold, then the Buyer is a protected consumer under the CPA.

11.3 The Seller's sole obligations and responsibilities to the Buyer in relation to the Goods shall be in terms of the warranty as set out in clause 10. Furthermore, insofar as this Agreement or the relevant transaction/s thereunder is/are subject to the provisions of the CPA, the Seller indemnifies the Buyer under the provisions of clause 17.4.1, if harm arising from the death or personal injury is caused by the Goods supplied by the Seller, subject to the limitations and/or exclusions and/or effects of sub-sections 61 (4) and 61 (6) of the CPA.

11.4 In amplification of the above, this Agreement is concluded without prejudice to any rights or defences which the Seller may have under the CPA, or otherwise at law in respect of any claims made or brought against it by the Buyer and/or any consumer or end-user protected under the CPA, or the purchaser of any Goods, supplied by the Seller.

12 INTELLECTUAL PROPERTY

12.1 The Seller and its licensors retain all Intellectual Property rights to, and in respect of, the Goods and related items. The Buyer shall only use the Goods and related items subject to this Agreement and for the purposes for which they have been developed, manufactured and supplied to the Buyer.

12.2 Without limitation to the above, the Buyer shall not have any right directly or indirectly to copy, reverse engineer or manufacture the Goods, or to license, lease, dispose of, distribute, disclose or otherwise exploit any Intellectual Property whatsoever of the Seller and its licensors, or any part thereof, or allow others to do so.

12.3 Should the Buyer become aware of any threatened or actual infringement of any Intellectual Property of the Seller or its licensors, then the Buyer shall forthwith, in writing inform the Seller accordingly and shall provide such cooperation and assistance as the Seller may reasonably require in the enforcement of its rights against any person.

12.4 In the event of any claim being proved by a third party in respect of an infringement of any Intellectual Property rights relating to any part of the Goods (other than a part based on a design or instructions furnished by the Buyer), the Seller shall at its expense and sole election either replace or modify such part with a non-infringing part or procure the right for the Buyer to use such a part, provided that the Seller is given full opportunity to conduct all negotiations in respect of such claim. Such claim shall not be acknowledged or settled by the Buyer without prior written consent of the Seller.

12.5 The Buyer warrants that any design or instructions furnished by it shall not be such as to cause the Goods to infringe any Intellectual Property rights of a third party.

13 CONFIDENTIALITY AND POPI

13.1 Confidential information includes, without limitation:

13.1.1 information relating to the Goods and the Intellectual Property, know-how, methods and techniques employed by a Party; and

13.1.2 financial and commercial information regarding this Agreement, or a Party in relation to its obligations pursuant to this Agreement.

13.2 Each Party shall not (and shall take all reasonable steps to ensure that its employees and agents shall not) for the duration of this Agreement, or at any time after the expiration or termination of this Agreement for any reason, disclose to any person (other than to its professional advisers on a need to know basis, or in compliance with a court order) or otherwise make use of any confidential information of the other Party.

13.3 Nothing in this clause 13 shall restrict the rights of either Party to use such information or documents for the purposes of legal enforcement of this Agreement in accordance with its terms

13.4 The Buyer is hereby notified, and therefore acknowledges, consents to and agrees that, in terms of the provisions of POPI and subject to this clause 13, the personal information supplied by it and the information relating to the Goods (collectively referred to as the "Data") is necessary and required for the successful conclusion of the transaction/s under this Agreement, the enforcement of rights and performance of obligations arising herefrom as well as the rendering of services in terms hereof, and that the Data will not be disclosed to any unauthorised parties.

13.5 The Buyer consents to the processing of the Data by the Seller in accordance with the provisions of this Agreement and POPI.

14 BREACH AND INSOLVENCY

14.1 Should either Party fail to remedy any breach of contract within 10 (ten) Business Days of a written request by the other Party to do so, then in such event that other Party may, without prejudice to any of its rights in terms of the Agreement or in law, cancel the Agreement by written notice with immediate effect, with or without claiming damages.

14.2 In the event that a Party:

14.2.1 commits an act of insolvency;

14.2.2 is placed under a provisional or final winding-up, or is subject to business rescue proceedings;

14.2.3 suffers that its credit rating is downgraded or its credit facilities withdrawn or rejected by any financial institution or credit bureau;

14.2.4 fails to satisfy or take steps to have set aside any judgment taken against it within 15 (fifteen) Business Days after such judgment has come to its notice;

then the other Party may terminate the Agreement on written notice with immediate effect.

14.3 Nothing in this clause 14 shall prevent a Party from claiming specific performance or damages for any breach, or from terminating the Agreement by written notice with immediate effect for any material breach of contract.

15 DISPUTE RESOLUTION AND GOVERNING LAW

15.1 The Seller shall always have the right to elect to institute action or any other form of litigation, for payment of the prices and any other amounts due under the Agreement in any court of competent jurisdiction. The Buyer agrees that this shall include any Magistrate's Court having jurisdiction over the Buyer, even if the claim or the value of the matter in dispute exceeds the monetary jurisdiction limit of the Magistrate's Court, and it accordingly hereby consents to the jurisdiction of such Magistrate's Court.

15.2 In the event of any disagreement or claim ("Dispute") arising out of or relating to this Agreement (including without limitation as to its existence or validity), the senior executives of the Parties or their delegates designated in writing shall endeavour to settle the Dispute through bona fide negotiations within 10 (ten) Business Days of the Dispute being referred to them by written notice from either Party.

15.3 Should the Parties be unable to settle the Dispute by the means and within the time frame stated above, either Party may refer the Dispute for final decision by arbitration in accordance with the rules for commercial arbitrations ("Rules") of the Arbitration Foundation of Southern Africa ("AFSA"), by one or more arbitrator/s appointed in accordance with the Rules.

15.4 Unless otherwise agreed in writing the arbitration shall be held in Pretoria and conducted in the English language. Only the Parties and their legal representatives or persons agreed to shall attend the arbitration proceedings.

15.5 The decision of the arbitrator/s may be made an order of court.

15.6 This Agreement shall in all respects be governed by the law of South Africa, without regard to its conflict of law provisions. The application of the United Nations Convention on Contracts for the International Sale of Goods (CISG) of 11 April 1980, shall be excluded.

15.7 This clause 15 is severable from the rest of the Agreement and shall survive the expiry or termination for whatsoever reason of the Agreement.

16 URGENT RELIEF

The provisions of clause 16 shall not preclude either Party from access to a competent court of law for relief in the form of an interdict, including a mandatory interdict or an order for specific performance.

17 LIMITATION OF LIABILITY AND INDEMNITY

17.1 Neither Party shall be liable to the other for any loss of profit, loss of use, interruption or reduction of operation, loss of data (including the recovery thereof), loss of production, loss of contracts or for any indirect or consequential damage that may be suffered by the other even

AGREED GENERAL TERMS & CONDITIONS OF SALES

if advised of the possibility of such damages and regardless of the form in which any action is brought. This waiver of all the classes of damages stated herein, shall survive termination of this Agreement for whatever reason.

17.2 Neither Party's aggregate liability to the other for any claim or claims for damages, out of or in connection with any cause arising from this Agreement, whether in contract or delict or any other cause of action, will in any event exceed 100 % (one hundred percent) of the value of the Goods and

Services supplied to the Buyer under this Agreement during the 12 (twelve) months immediately prior to the events leading to the cause of action.

17.3 Nothing contained in clauses 17.1 and 17.2 above shall limit either Party's liability to the other in respect of:

17.3.1 death or injury of any person, or damage to property;

17.3.2 infringement of Intellectual Property rights;

17.3.3 breach of confidentiality;

17.3.4 the warranties and indemnities contained in the Information Warranty and clauses 5.3, 6.4.2 and 12.5; or

17.3.5 intentional, fraudulent or criminal acts.

17.4 Subject to clauses 16.1, 16.2 and 16.3 above, each Party (the "Indemnifying Party") agrees to defend, indemnify and hold the other Party, its directors, employees, agents and other members of its group of companies, as that term is defined in the Companies Act 71 of 2008, (each an "Indemnified Party") harmless from any claim, damage, cost, liability and expense including reasonable attorney's fees caused by, relating to or arising from:

17.4.1 the acts or omissions of the Indemnifying Party, its directors, employees or agents;

17.4.2 any alleged delict, or breach of any contractual right of a third party, or infringement of any Intellectual Property rights of a third party, or confidentiality obligations, or rights of privacy and publicity resulting from, relating to or arising out of the acts or omissions of the Indemnifying Party, except where any such claim relates to or arises out of any material furnished by the Indemnified Party.

17.5 The Parties will co-operate in the defence of any matter arising from an indemnity under clause 17.4. A Party has the right to participate in the conduct of the defence with legal counsel chosen by it.

18 NOTICES AND DOMICILIUM

18.1 For the purposes of this Agreement, including the giving of notices and the serving of legal process, the Seller chooses the address set out in clause 1.1.1.1 above, and the Buyer chooses the address as set out in the Physical address of the form, as their respective domicilia citandi et executandi.

18.2 Any notice addressed to a Party shall be delivered by hand during office hours to its physical address, and shall be deemed to be received (unless the contrary is proved) on the day of delivery.

18.3 Although the Parties may correspond via electronic mail for operational purposes, no valid notice under, or amendment to the terms of, this Agreement may be given or concluded by way of a data message as defined in the Electronic Communications and Transactions Act, 25 of 2002.

18.4 A Party may by written notice to the other Party change its domicilium to another address in South Africa which is not exclusively a post office box or poste restante. The change will become effective on the 5th (fifth) day following deemed receipt of the notice.

18.5 No provision of this domicilium clause shall be taken as affecting the validity of any notice which is actually received by a Party, whether at its domicilium or not and whether delivered in terms of the express provisions of this domicilium clause or not and any notice which is actually received by a Party shall be deemed to be notice validly given.

19 COMPLIANCE WITH LAWS AND ANTI-CORRUPTION

19.1 Each Party shall in all matters arising from or relating to the fulfilment of this Agreement conform at its own expense with all laws and legislation relevant hereto.

19.2 The Parties shall not be entitled to claim or receive any benefits or rewards arising from the Agreement, other than specifically provided for in this Agreement.

19.3 Each Party confirms that neither it nor any of its employees, associates or agents have committed, or admitted to, or have been convicted of, any Corrupt Act in relation to the Agreement and that it has ensured that all anti-corruption laws, internal processes and anti-corruption preventative measures have been complied with, prior to Signature Date. Each Party will further ensure that all anti-corruption laws, internal processes and anti-corruption preventative measures will continue to be complied with for the duration hereof.

19.4 Failure by a Party to comply with this clause 19 shall constitute a material breach of contract.

20 GENERAL

20.1 Validity and Severability

If any provision of this Agreement is found or held to be invalid or unenforceable, the validity of all the other provisions hereof will not be affected thereby and the Parties agree to meet and review the matter, and if any valid and enforceable means is reasonably available to achieve the same objective as the invalid or unenforceable provision, to adopt such means by way of variation of this Agreement.

20.2 Contra Proferentem

The rule of construction that in the event of any uncertainty in any provision in any agreement, such agreement shall, in construing/interpreting the uncertainty, be construed or interpreted against the drafter of such agreement, shall not be applicable to this Agreement.

20.3 Variation

No variation or cancellation of, or addition to this Agreement will be of any force or effect unless reduced to writing and signed by the Parties.

20.4 Indulgence and Waiver

20.4.1 No indulgence, extension of time, relaxation or latitude which a Party may show, grant or allow to the other Party, shall constitute a waiver by it of any of its rights and it shall not thereby be prejudiced or **estopped** from exercising any of its rights against the other Party which may have arisen in the past, or which might arise in the future.

20.4.2 No waiver or abandonment on the part of a Party of any rights arising from a breach of any provision of this Agreement:

20.4.2.1 will constitute a waiver or abandonment of rights in respect of any subsequent breach of the same or any other provision, and

20.4.2.2 shall be binding on it unless such waiver or abandonment is in writing and signed by it.

20.5 Force Majeure

20.5.1 Failure to comply with any of the terms and conditions of the Agreement if occasioned by or resulting from an act of nature or public enemy, fire, explosion, earthquake, perils of the sea, flood, storm or other adverse weather conditions, war declared or undeclared, civil war, revolution, civil commotion or other civil strife, riot, strikes, blockade, embargo, sanctions, epidemics, act of any government or other authority, compliance with government orders, demands or regulations, as well as shortages, interruptions, fluctuations or the unavailability of electrical power, water supply or means of communication or any circumstances of like or different nature beyond the reasonable control of the Party so failing ("force majeure"), will not be deemed to be a breach of the Agreement, nor will it subject either Party to any liability to the other.

20.5.2 Should a Party's performance of an obligation become temporarily impossible owing to force majeure, that Party shall:

20.5.2.1 as soon as reasonably possible after the force majeure sets in notify the other Party in writing of the incidence of force majeure;

20.5.2.2 be released from performance of the affected obligation for so long as the force majeure prevails;

20.5.2.3 use its best endeavours to recommence performance of the affected obligation, to whatever extent reasonably possible, without delay; and

20.5.2.4 co-operate with the other Party in implementing such contingency measures as the other Party may reasonably require.

20.5.3 If some of the Goods (or any part thereof) ordered under a PO have been delivered, but not all of the Goods (so ordered under that PO) as a result of force majeure, the Buyer shall pay to the Seller that proportion of the stated price appropriate to the Goods (or any part thereof) which have been delivered.

20.5.4 Should the circumstances of force majeure continue for longer than 20 (twenty) Business Days, either Party shall be entitled to terminate the relevant PO, or if appropriate the Agreement, with immediate effect by written notice.

20.6 Cession and Delegation

A Party cannot validly cede any right or delegate any obligation arising under this Agreement without the prior written consent of the other Party, which consent shall not be unreasonably withheld. Notwithstanding the above, the Seller may by written notice to the Buyer cede and delegate this Agreement to any other company controlled by Reunert Limited 1913/004355/06.

20.7 Warranties

No Party has given any warranty or made any representation to the other Party, other than as expressly set out in this Agreement. No Agency

20.8 No Agency

The Seller is an independent contractor of the Buyer and nothing in this Agreement constitutes a relationship of employment, agency, joint venture or partnership between the Parties. A Party shall not hold itself out as being an agent or partner of the other Party, or as being in a joint venture with the other Party. A Party shall not assume or create or attempt to assume or create directly or indirectly any obligation on behalf of or in the name of the other Party.

20.9 Co-operation and Support

Each Party undertakes at all times to use commercially reasonable efforts to co-operate, to perform all such actions and take such steps and to procure the cooperation, the performance of all such actions and taking of all such steps as may be open to it and necessary for and incidental to the putting into effect and maintenance of the provisions of this Agreement.

20.10 Non Solicitation

A Party shall not, at any stage after the commencement of this Agreement, and for a period of 12 (twelve) months after this Agreement has terminated, make any offers of employment to any Staff Member, who is or has been employed by the other Party and has been involved in the execution of this Agreement. The aforementioned restraint shall not be applicable in the event where the prior written approval to make such an offer has been obtained from the other Party who is or has been the employer of such Staff Member. For the purpose of this clause "Staff Member" shall include permanent and part-time employees of a Party, and of a Party's suppliers under this Agreement. Should a Party breach this restraint, it shall pay as liquidated damages to the other Party upon such breach an amount equivalent to the gross annual salary as calculated immediately prior to the breach (including any commissions and other payments) of such Staff Member.

20.11 Entire Agreement

The terms contained in this Agreement constitute the entire agreement between the Parties with respect to the subject matter hereof, superseding all contemporaneous oral agreements and prior oral and written quotations, communications, agreements, and understanding of the Parties.

20.12 Language

The ruling language of this Agreement and for communications and notices shall be English. All documents, manuals, certificates, notices, materials and training, if any, to be supplied by a Party under this Agreement shall be in English.

20.13 Costs

20.13.1 Each Party shall bear its own legal costs and disbursements of and incidental to the negotiation, preparation, settling, signing and implementation of this Agreement.

20.13.2 Any legal costs incurred by a Party arising out of or in connection with a breach by the other Party, shall be borne by the Party in breach on a scale as between attorney and client, including but not limited to, collection charges and tracing costs.

Refer to our website for the full Term's and Conditions of Sales

CIRCUIT BREAKER INDUSTRIES PRODUCT WARRANTY

All products sold are subject to the Circuit Breaker Industries (Pty) Ltd General Terms and Conditions of Sale. The applicable product warranties are depicted in Table 1 below:

CIRCUIT BREAKER INDUSTRIES PRODUCT WARRANTIES				
Product Range	Type	Technology	Warranty	Note
CBE - B / C / DD / Y	CBE	Hydraulic-Magnetic	60 Months	Warranty is from date of manufacture
QA / QF / QDC	MCB - Clip In	Hydraulic-Magnetic	60 Months	
GD / FD / KD / LD / ND / MB / NF / NV / DSN	MCCB	Thermal-Magnetic / Electronic	24 Months	
AE	ACB	Thermal-Magnetic / Electronic	24 Months	
LB / JSO	MCCB	Hydraulic-Magnetic	60 Months	
QA17 / QF17 / QA36 / SF15 / SF36 / SM15 / SM36	Earth Leakages	Hydraulic-Magnetic	12 Months	
QAT-TRDM / SAK	Auxiliary Products	Various	12 Months	
QFL / QKL	Surge	Various	12 Months	
Astute	Various	Various	12 Months	
Wiring Accessories	Various	Various	12 Months	
All other products not specifically mentioned	Various	Various	12 Months	

Table 1: Product Warranties

Exclusions

All products returned to Circuit Breaker Industries (Pty) Ltd under warranty claim will be subject to a failure investigation to determine the validity of the communicated failure. The following conditions are not considered as a product failure, as such will not qualify as a warranty claim:

- Any unofficial Product Modification
- Any incorrect Product Application
- Any tampering with the Product Seal or Date Stamp / Coding
- Any damage resulting from Lightning, Water or Dust (Environmental Disturbances and Quality of Supply)
- Any failure caused as a result of VIZ MAJOR

SOUTH AFRICA HEAD OFFICE CBI-electric: low voltage

- 📍 Tripswitch Drive, Elandsfontein, Gauteng, South Africa
- ☎ +27 11 928 2000
- ✉ cbi@cbi-electric.com
- 🌐 www.cbi-lowvoltage.com

Branches:

BLOEMFONTEIN (Free State / Northern Cape)

- 📍 Unit 8, Plot 44, Eland Street, Quaggafontein, Bloemfontein, Free State, 9301
- ☎ (051) 430 8613/4
- ☎ (051) 430 1141
- ✉ bfm@cbi-electric.com

DURBAN (KwaZulu-Natal)

- 📍 10 Heron Park, 80 Corobrik Rd, Riverhorse Valley, KwaZulu-Natal, 4017
- ☎ (031) 569 1087
- ☎ (031) 569 6455
- ✉ dbn@cbi-electric.com

CAPE TOWN (Western Cape)

- 📍 Unit 5 Stanford Business Park, 24 Assegaa Road, Parow Industria, Cape Town, Western Cape, 7493
- ☎ (021) 928 1388
- ☎ (021) 928 1389
- ✉ ctn@cbi-electric.com

GQEBERHA (Eastern Cape)

- 📍 Unit 7, Pickering Square, 84 Pickering Street, Newton Park, Gqeberha, Eastern Cape, 6045
- ☎ (041) 374 1270/1/2
- ☎ (041) 373 1919
- ✉ pe@cbi-electric.com

International Offices:

USA

CBI-electric: North America

- 📍 600 Eagleview Blvd, Suite 300, Exton, PA, USA, 19341, United States
- ☎ +1 610 524 9949
- ☎ +1 610 524 9945
- ✉ info@CBIBreakers.com
- 🌐 www.cbibreakers.com

AUSTRALIA

CBI-electric: Australia

- 📍 33 Bazalgette Cres, Dandenong South, VIC, 3175, Australia
- ☎ +1800 770 870
- ✉ sales@cbi-electric.com.au
- 🌐 www.cbi-electric.com.au

INDIA

CBI-electric: Asia

- 📍 27/A, Nitesh Rio, Adjacent to Vakil Garden, Thalaghattapura, Kanakapura Road, Bengaluru, India, 560109
- ☎ +91-9880553153
- ✉ salesasia@cbi-electric.com
- 🌐 www.cbi-lowvoltage.com



Website



LinkedIn



Facebook



YouTube



Instagram



TikTok

Proud Local Manufacturer

© 2025 CBI (Pty) Ltd. All Rights Reserved.

All rights reserved. Unless otherwise indicated, all materials on these pages are copyrighted by CBI (Pty) Ltd. No part of these pages, either text or image may be used for any purpose other than personal use. Therefore, reproduction, modification, storage in a retrieval system or retransmission, in any form or by any means, electronic, mechanical or otherwise, for reasons other than personal use, is strictly prohibited without prior written permission. CBI (Pty) Ltd reserves the right to alter any details of this document / agreement without notice and while every effort is made to ensure the accuracy of the content, no warranty is given as to the accuracy of this document and no responsibility will be accepted for error or misinterpretation and any resulting loss.